

HARLEM 15

Bowl and a half granite sink with drainer

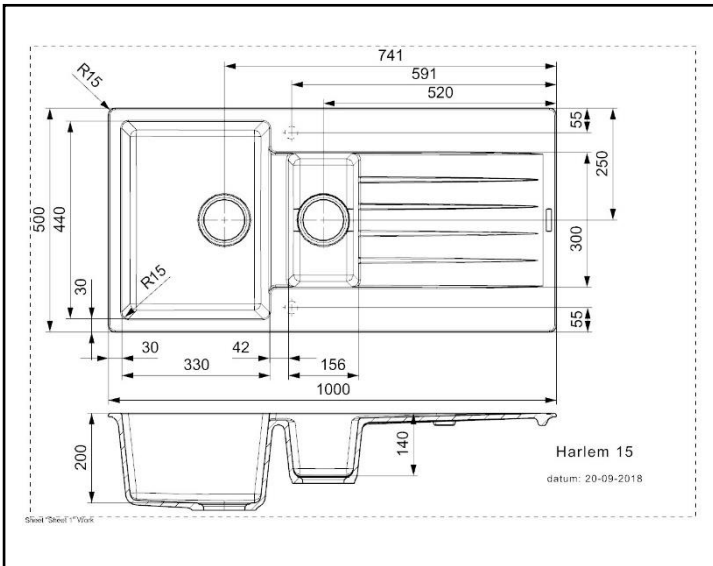
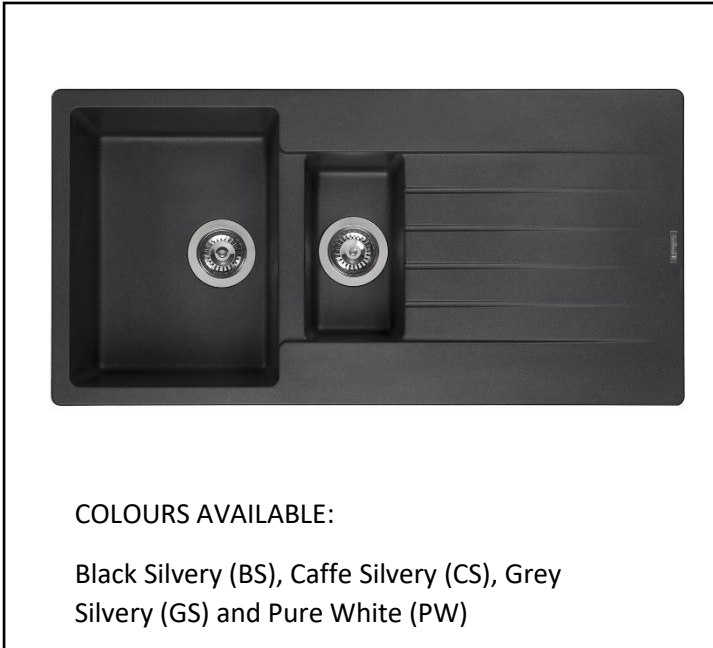

FEATURES & BENEFITS			
10 YEAR WARRANTY (sink only)	1.5 BOWL	2 X 35MM TAP HOLES	2 X 90MM WASTE INCLUDED
FIXING CLIPS INCLUDED	REVERSIBLE	HALF BOWL ACTS AS OVERFLOW	600MM BASE UNIT

SPECIFICATION

Colours	BS, CS, GS, PW
Material	Granite
Installation	Inset Only
Tap Holes	2 tap holes partially drilled
Base Unit	600mm
Steel Gauge	N/A

DIMENSIONS

Product Dimensions	1000 x 500 x 200/140mm
Product Weight	25KG
Box Dimensions	1100 x 590 x 275mm
Packed Weight	27KG

CARE & MAINTENANCE

Routine Maintenance

The best way to clean your sink is with a microfibre cloth or a soft sponge and using non-abrasive cleaning products. We do NOT recommend the use of bleach on any of our granite products. After cleaning the granite sink we recommend that you rinse the surface with warm water, carefully drying the area with a soft cloth.

General Advice

We recommend that you regularly use a descaling detergent that prevents stains and the formation of calcareous deposits.

When cleaning do not use any sharp or abrasive equipment.

Do not leave leftover food or liquids on the bottom of the as extended contact with such products could lead to discolouration of the sink.