

# Dura Plus LED Battery Light

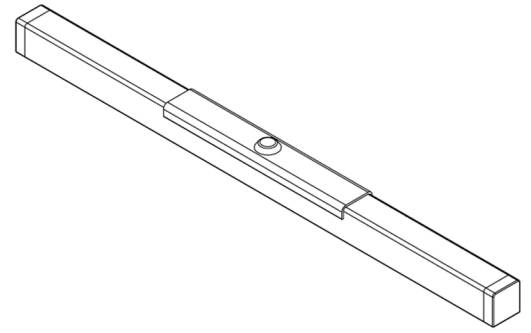

**CODE: SE16097C0**

## INSTALLATION INSTRUCTIONS

**IMPORTANT:** Please read these instructions before commencing installation and retain for future reference.

### Components

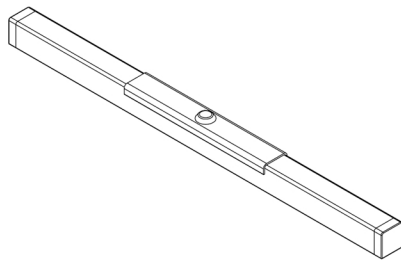

1 x Dura Plus Light

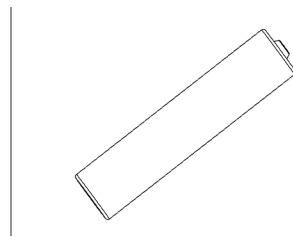

4 x AAA Batteries  
(Not Included)

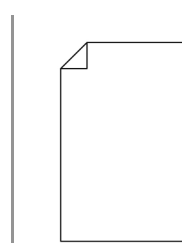

1 x Instruction  
Manual

### Tools required

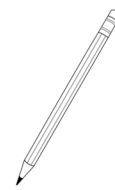

1 x Pencil

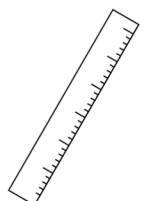

1 x Ruler

### Important Safety Information

Please read these instructions carefully before attempting to install this product. It is advisable to keep these instructions in a safe place for future reference.

These products must not be modified, if any modifications are made, it may invalidate the warranty and may render the product unsafe.

This product is for indoor use only. Keep out of moisture and use only in dry rooms.

- Install on smooth flat surface(s) only.
- This product is IP20 Rated.
- The wattage for each light is 1W.

### Safety Instructions

1. The lights should be mounted onto a secure surface.
2. Suitable for furniture lighting.
3. When the lamp expires the fitting must be replaced
4. Class III safety extra low voltage (SELV).

#### Waste Electrical & Electronic Equipment (WEEE)

The symbol on the product, or on the document accompanying the product, the crossed out wheelee bin symbol, indicates that this product may not be treated as household waste. Instead it shall be handed over to the applicable collection point for the recycling of electrical and electronic waste.



**RoHS**  
Compliant ✓ **CE**

Sensio House, Unit 7, Speedwell Road, Whitwood, Castleford, West Yorkshire, WF10 5PY

[www.sensio.co.uk](http://www.sensio.co.uk)

Technical drawings for illustration purposes only, Sensio has the right to change any information without prior notice.

**Installation**

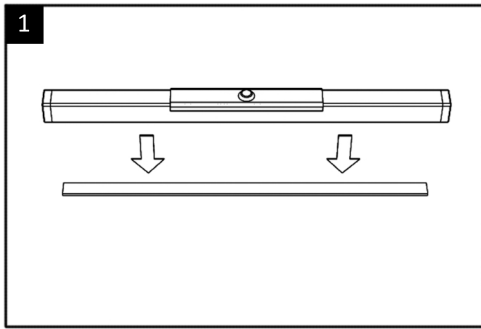

Remove the magnetic strip from the bottom of the Dura Plus.

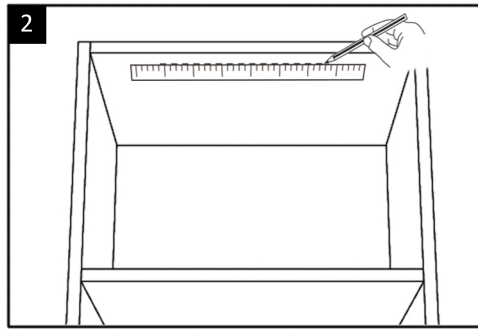

Using a pencil and ruler, carefully mark out the desired location for the magnetic mounting strip.

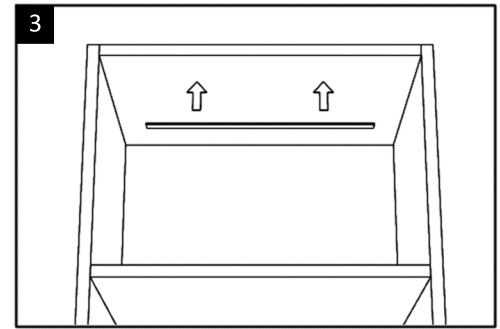

Remove the paper protecting the adhesive on the back of the magnetic strip and stick it into your desired position.

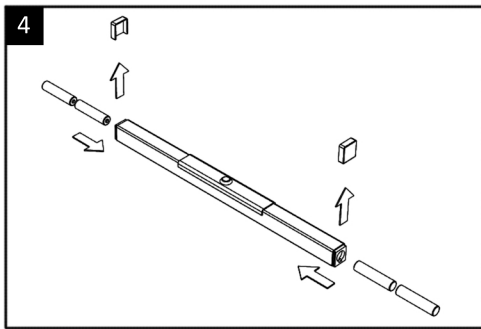

Remove the two end-caps and insert four AAA batteries.

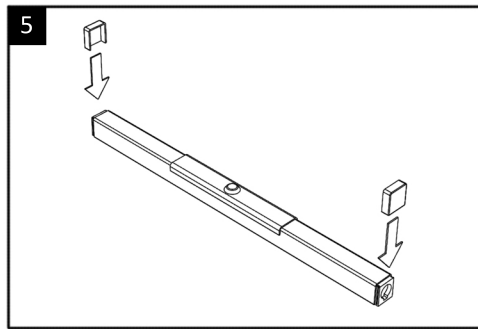

Slide the end-caps back into position.

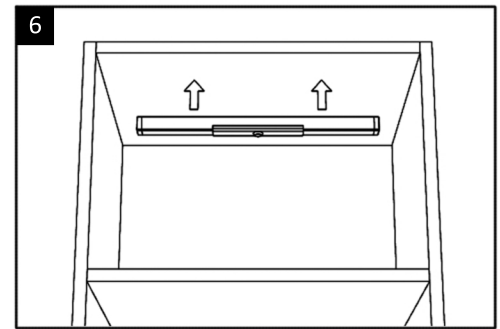

Attach the Dura Plus to the magnetic strip.

**Function**

**PIR Sensor**

The PIR sensor will sense any movement within the detection range and trigger the light source.

**Detection Range**

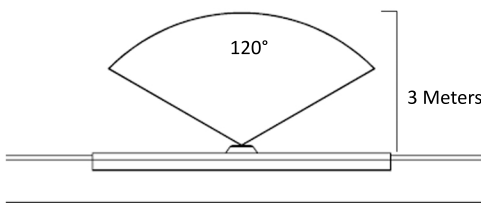

**PIR Sensor - Time Control Switch**

**Left** - Sets the timer to 60 seconds  
**Right** - Sets the timer to 20 seconds

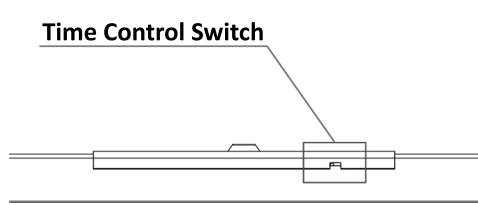

**Key Selling Points:**

- The product features an integrated PIR sensor, so the light source is triggered by movement.
- The product is battery powered, which makes it perfect for retro fitting.
- Installation is made quick and simple by the magnetic mounting plate.

**Maintenance & Care**

- To keep the finish of this product, wipe over with soft cloth periodically.
- Do not use harsh chemical solvents, this may dis-colour or damage the finish.