

BLUMOTION

by Blum

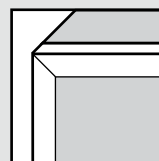
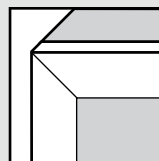
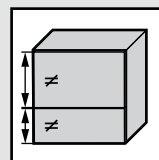
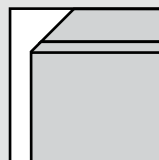
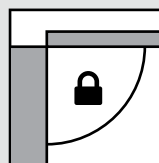

AVENTOS HF

www.blum.com

 **blum**®

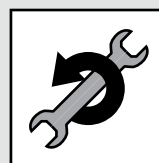
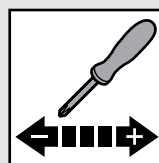
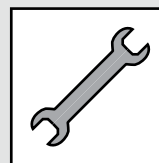
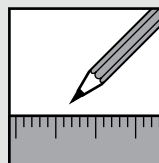

AVENTOS HF

 blum

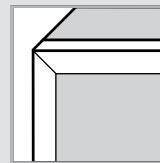
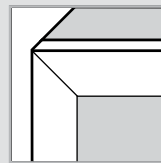
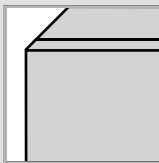
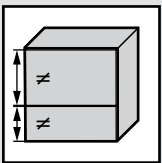
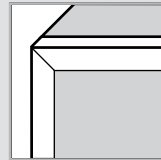
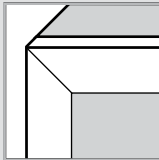
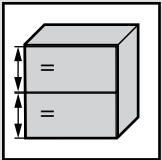
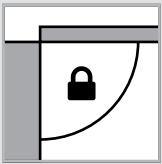
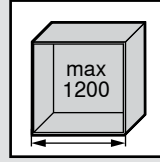
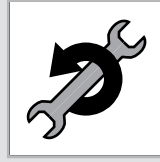
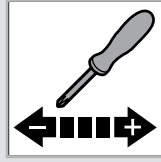
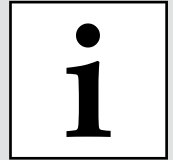

Planung | Planning | Planification |
Progettazione | Planificación | Planowanie |
Проектирование

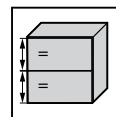

Symmetrisch | Symmetrical | Symétrique | Simmetrico |
Simétrico | Symetryczne | Симметрично



Montage | Assembly | Montage | Montaggio |
Montaje | Montaž | Монтаж

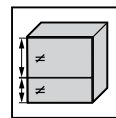

Asymmetrisch | Asymmetrical | Asymétrique |
Simmetrico | Asimétrico | Asymetryczne |
Асимметрично



Einstellung | Adjustment | Réglage | Regolazione |
Ajuste | Regulacja | Регулировка

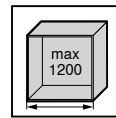

Korpusbreite | Cabinet width | Largeur corps de meuble |
Larghezza corpo mobile | Ancho de cuerpo de mueble |
Szerokość korpusu | Ширина корпуса

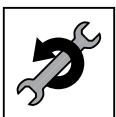

Demontage | Removal | Démontage | Smontaggio |
Desmontaje | Demontaž | Демонтаж

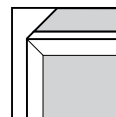

Schmaler Alurahmen | Narrow alu frame | Cadre alu
étroit | Telai in alluminio stretti | Marcos de alumi-
nio estrechos | Wąskie ramki aluminiowe | Узкая
алюминиевая рамка

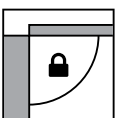

Öffnungswinkelbegrenzer | Opening angle stop |
Limiteur d'angle d'ouverture | Limitatore angolo di
apertura | Limitador de apertura | Ogranicznik kąta
otwarcia | Ограничитель угла открывания

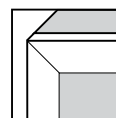

Breiter Alurahmen | Wide alu frame | Cadre alu large |
Telai in alluminio larghi | Marcos de aluminio anchos |
Szerokie ramki aluminiowe | Широкая алюминиевая
рамка



Klickbar | Clickable | Cliquable |
Cliccabile | Se puede hacer clic |
Klikalny | Кликабельно



Nicht Klickbar | Not clickable |
Pas cliquable | Non cliccabile |
No se puede hacer clic |
Nie klikalny | Некликабельно



Zurück | Back | Retour | Indietro |
Hacia atrás | Wstecz | Назад

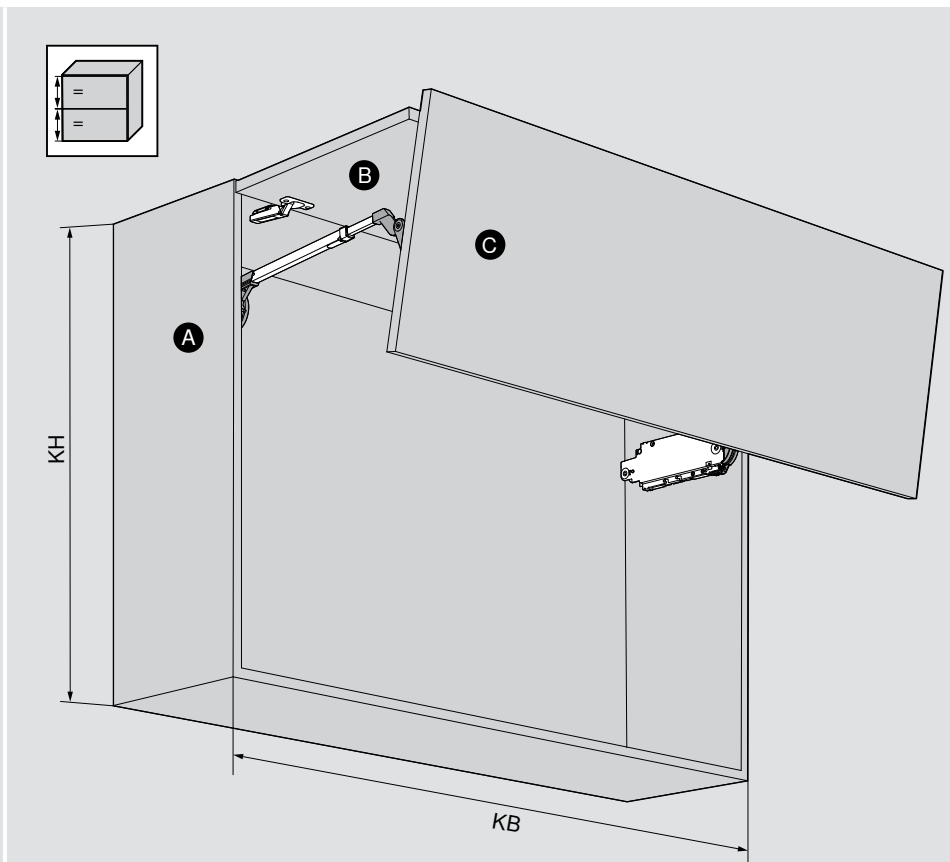
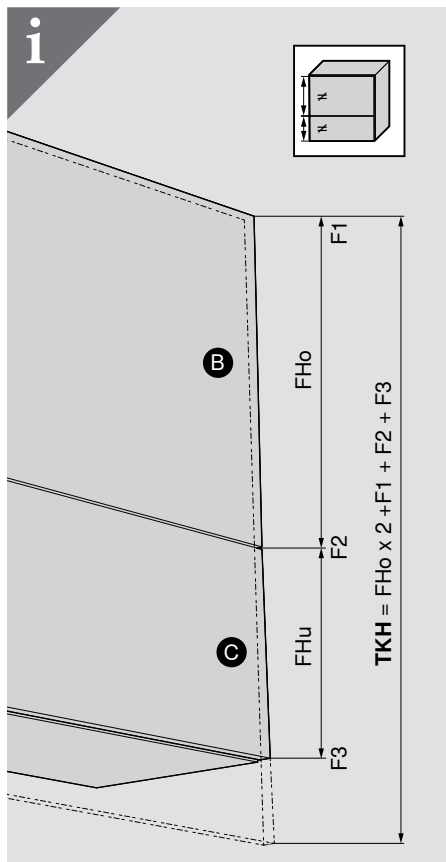
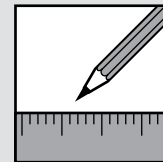

1 KH | TKH: 480 – 549 → KH | TKH x 0.3 - 28 = H
 KH | TKH: 550 – 1040 → KH | TKH x 0.3 - 57 = H

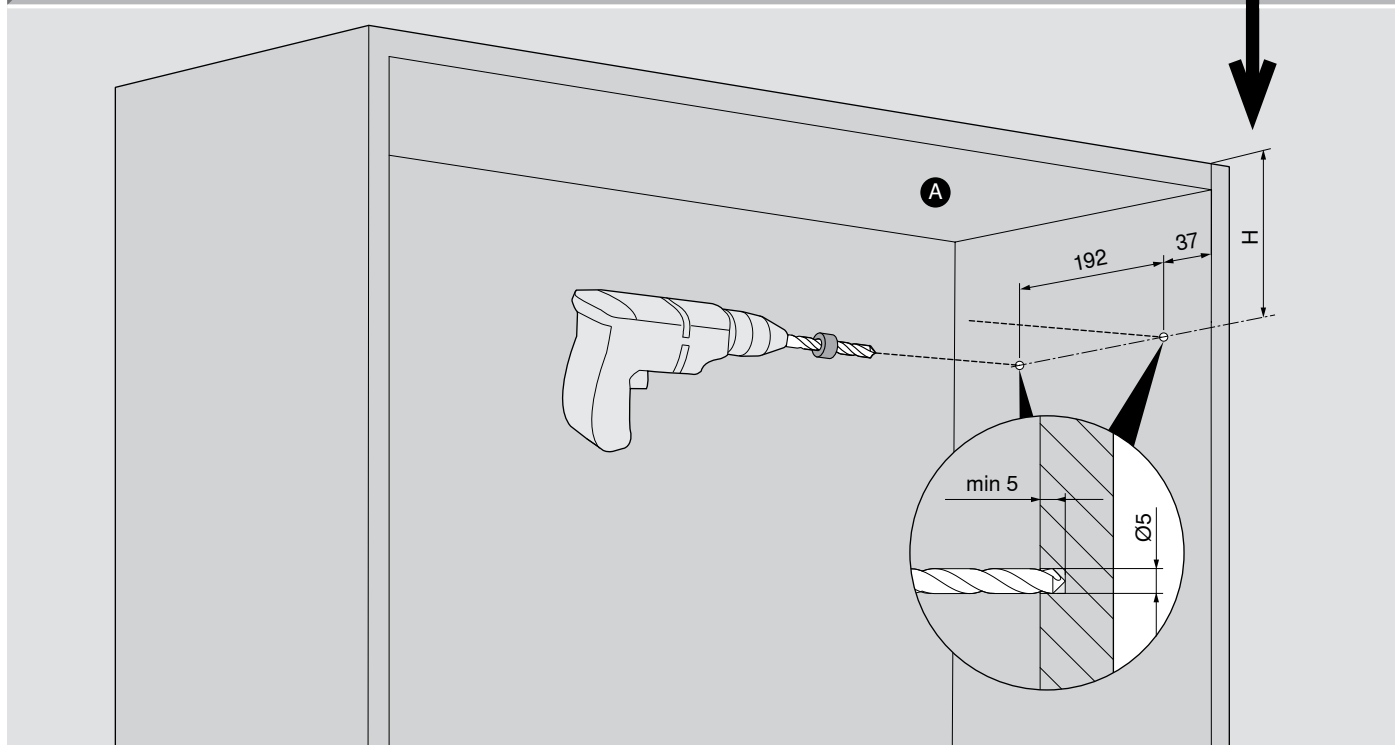



2

2 x

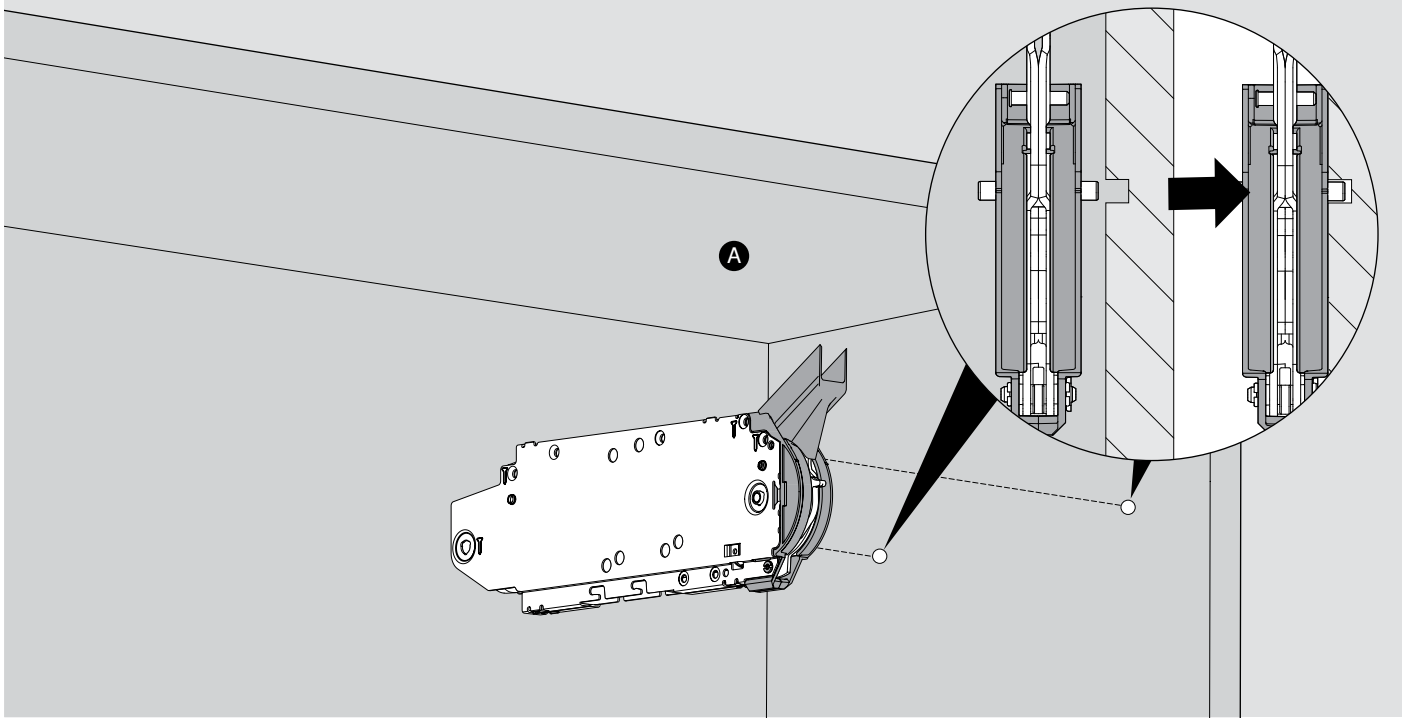
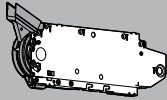

3

4 x (3.5 x 15)

2 x

8 x (4 x 35)

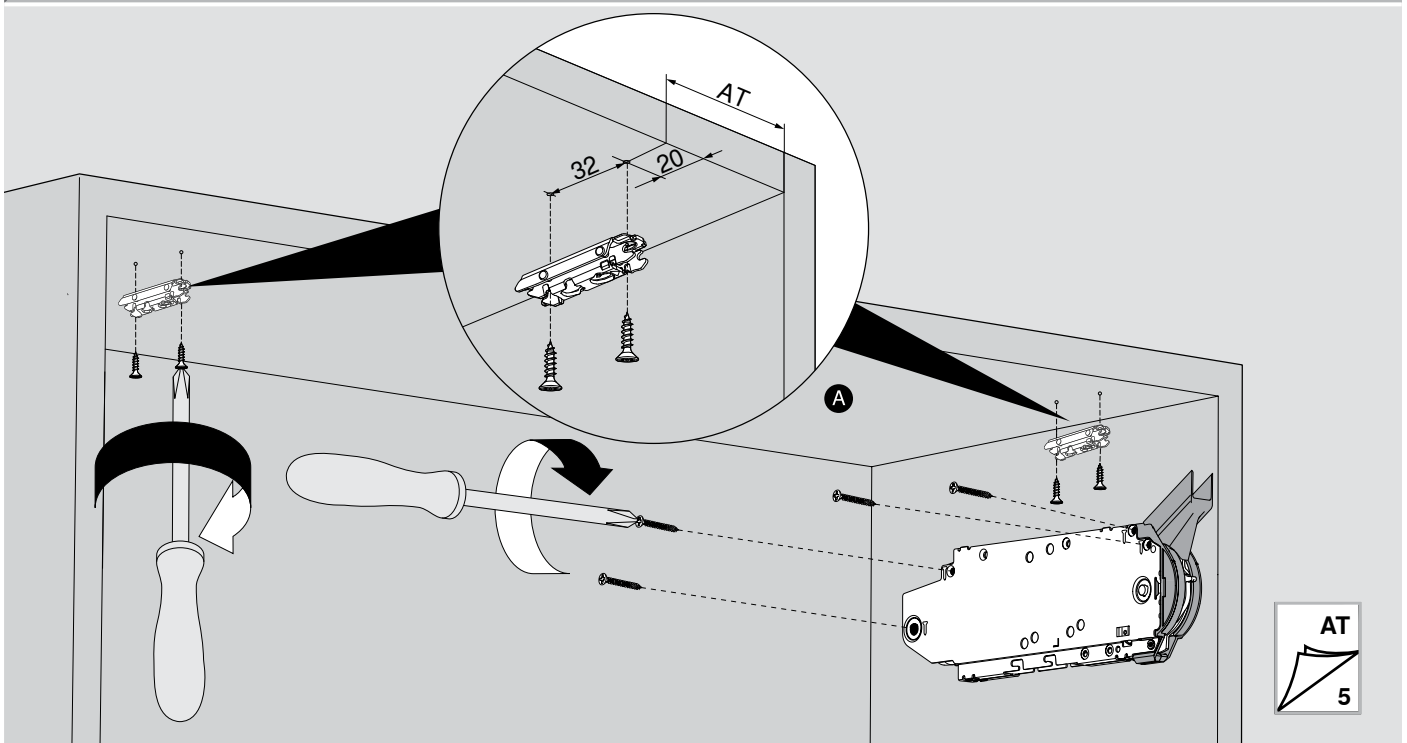

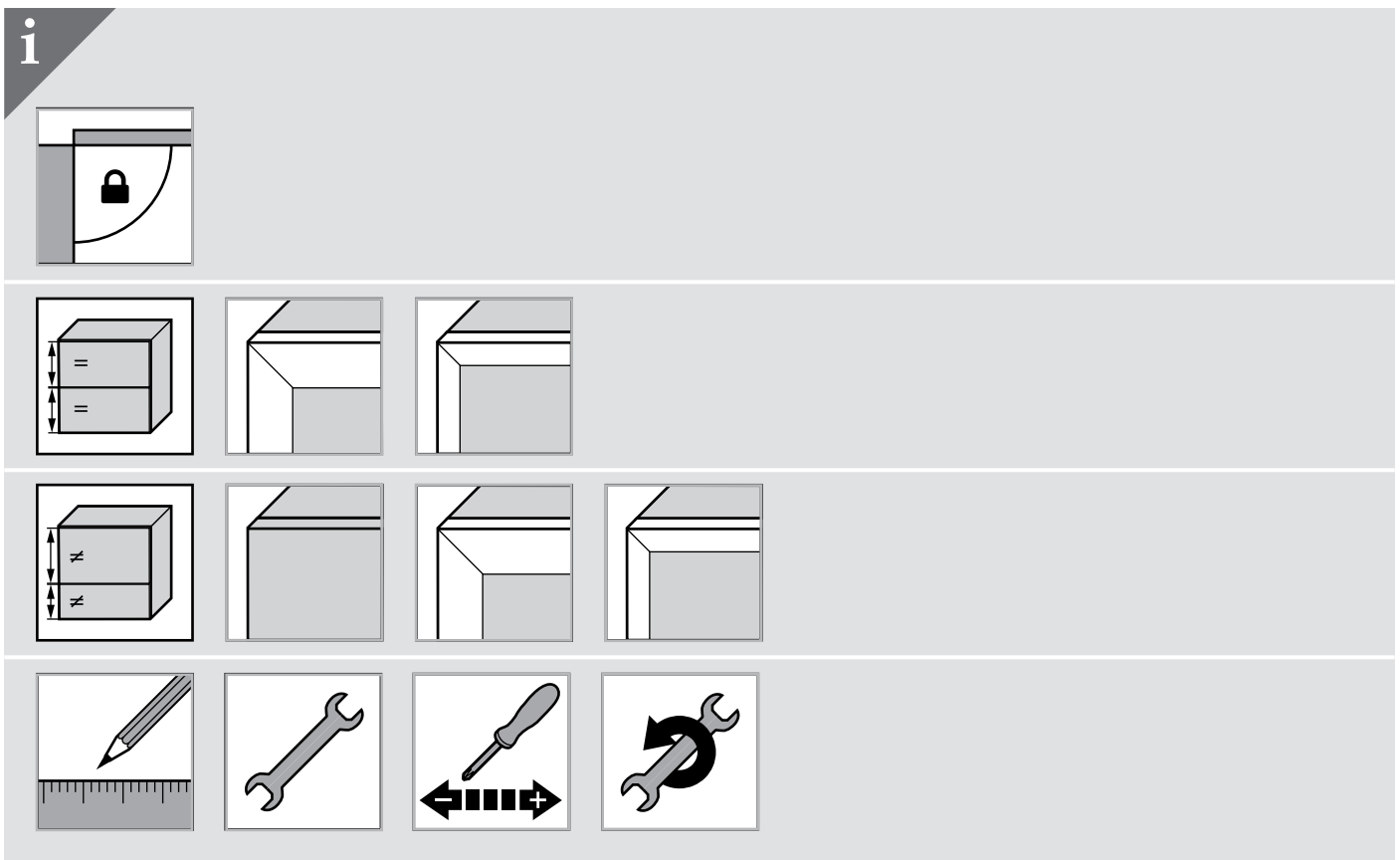
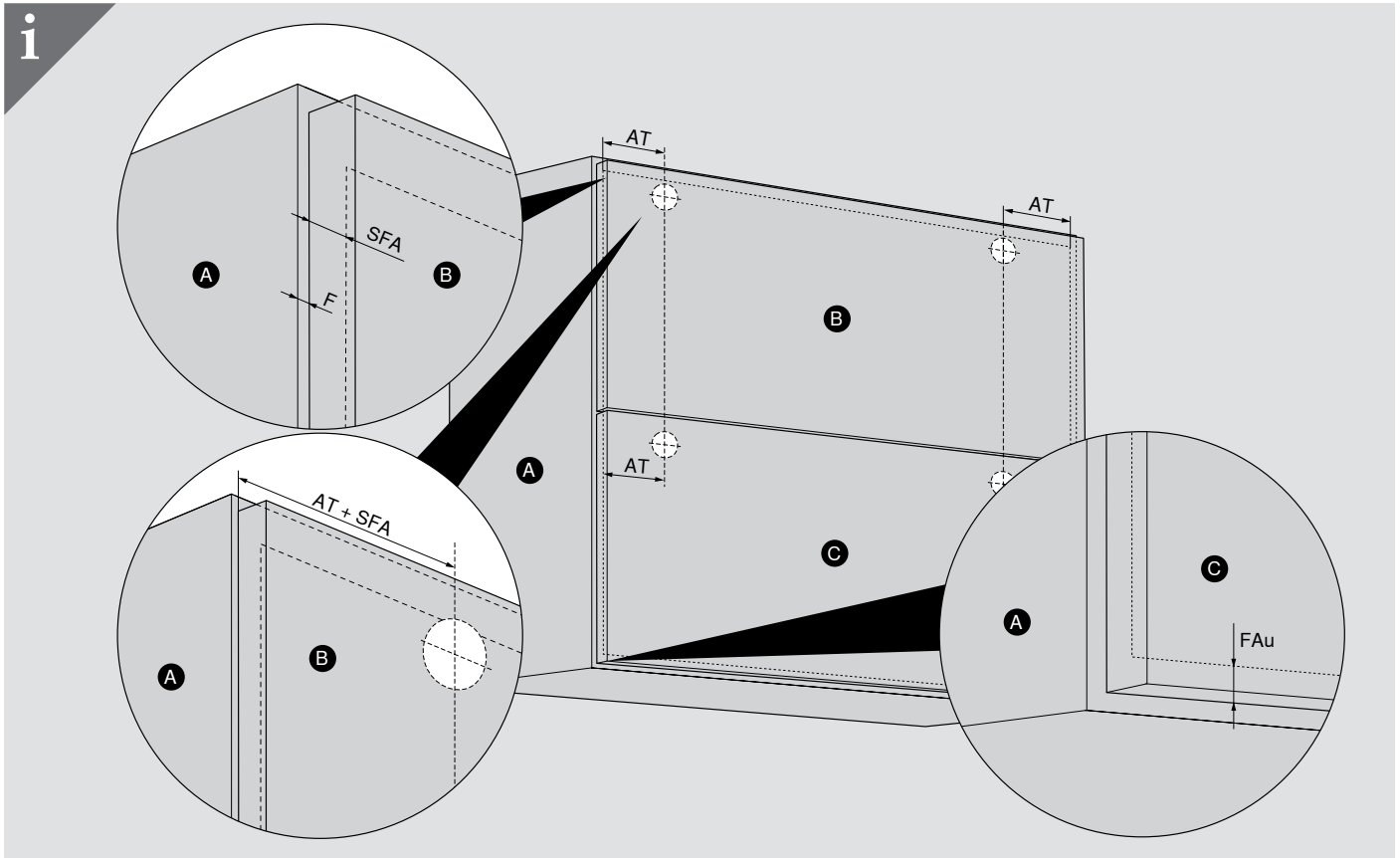
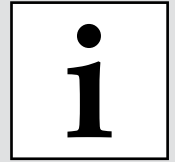

AVENTOS HF

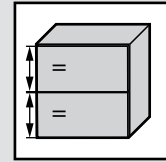
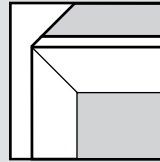

i

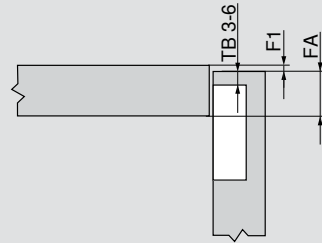
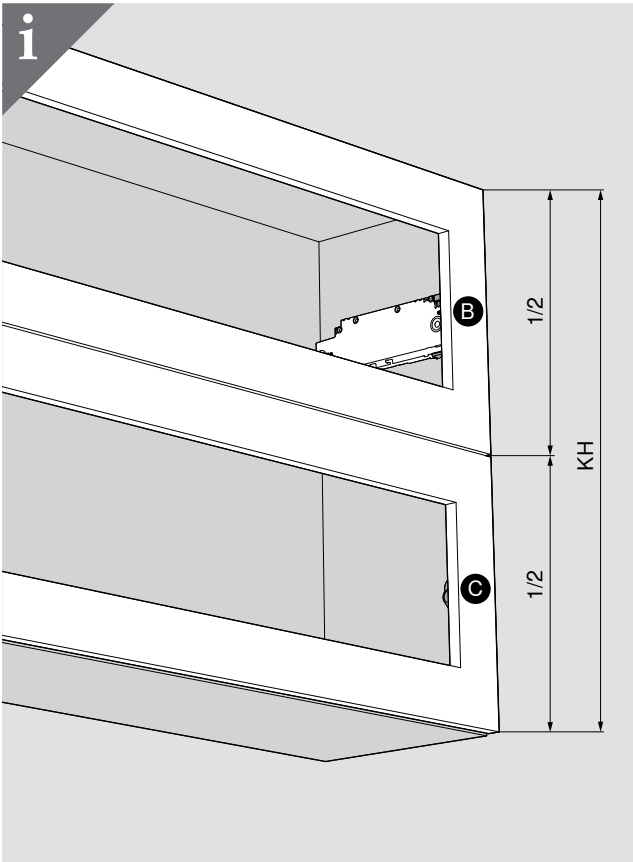

		FA																TB
		5	6	8	8	9	10	11	12	13	14	15	16	17				
MP	0												3	4	5	6		
	3								3	4	5	6						
	6				3	4	5	6										
	9	3	4	5	6													

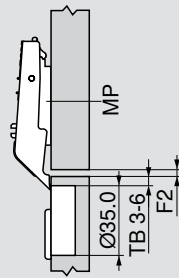

		F				TB
		3	4	5	6	
MP	0	6	5	4	3	
	3					
	6					
	9					

1

8 x (3.5 x 9.5) 2 x 2 x

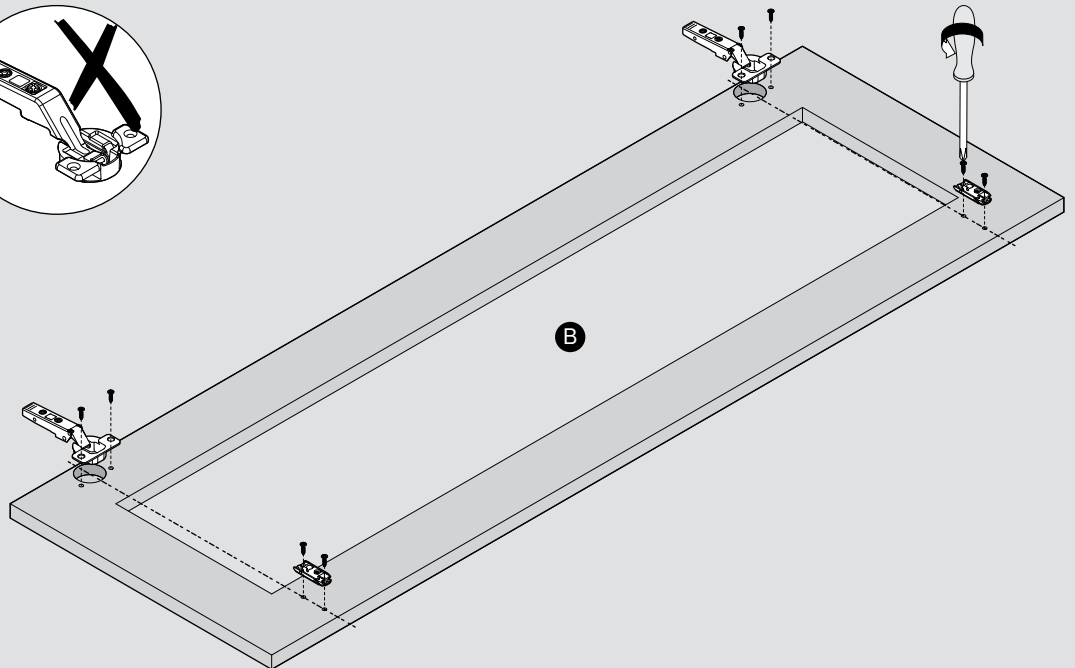
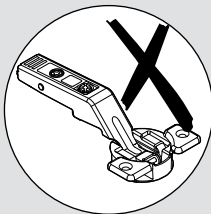
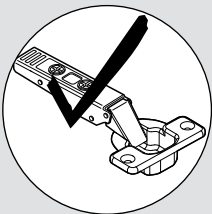

AVENTOS HF

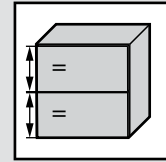
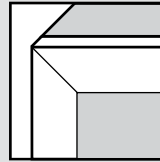

2

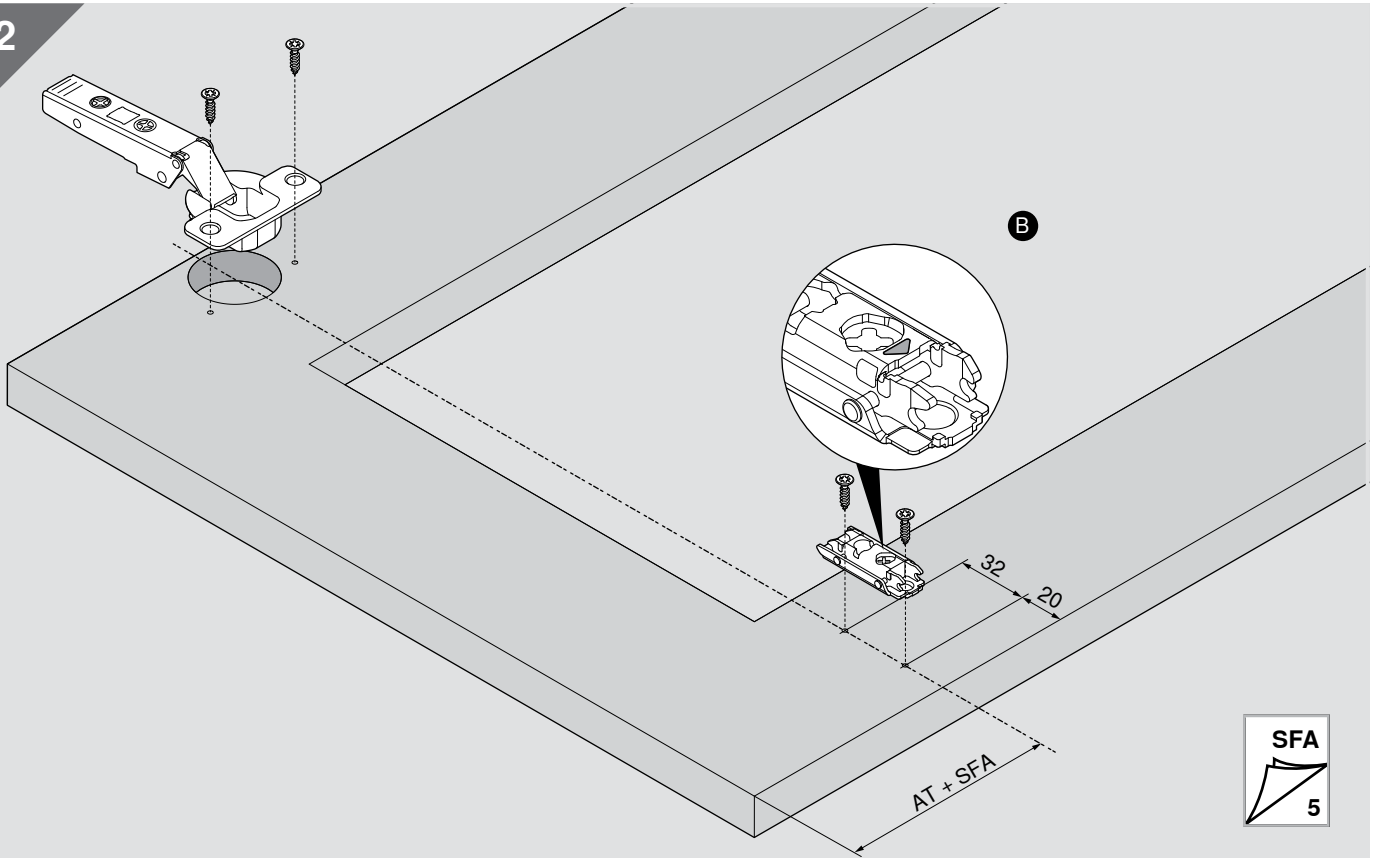

3

- 8 x (3.5 x 9.5) 2 x 2 x

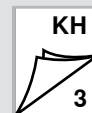
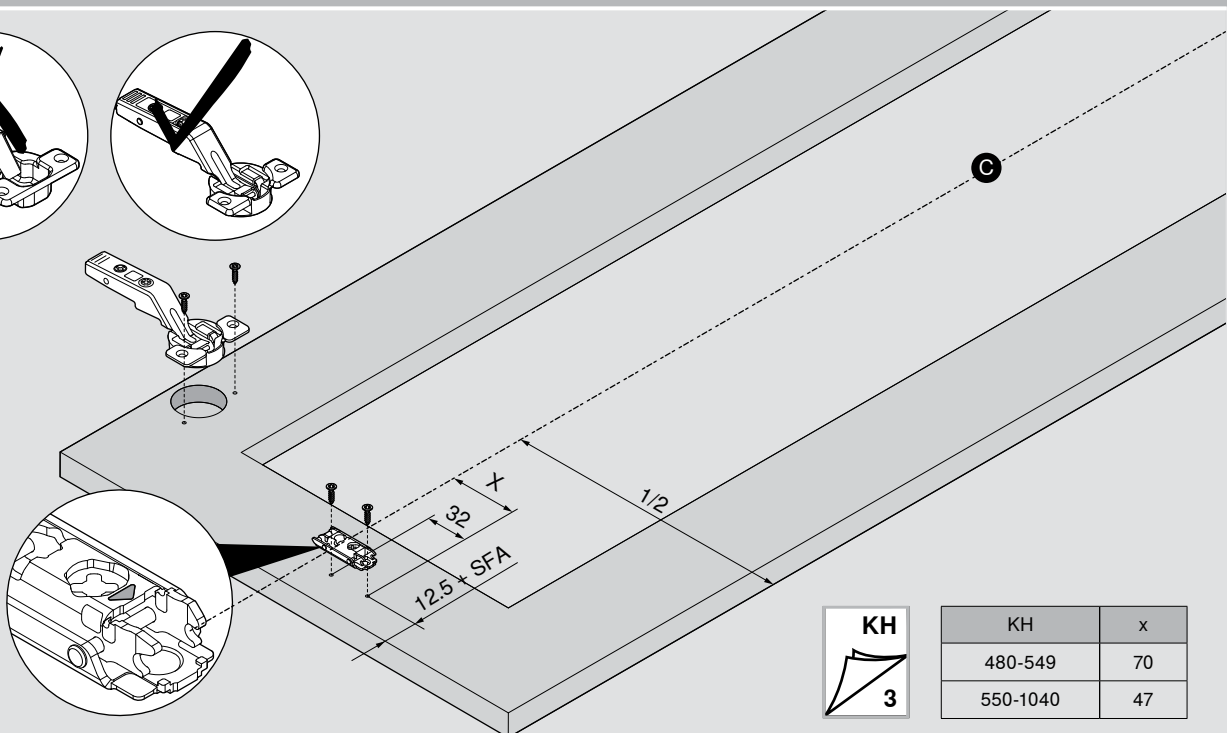
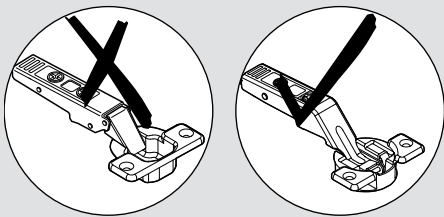

KH	x
480-549	70
550-1040	47

AVENTOS HF

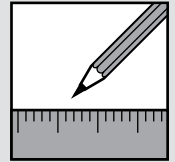
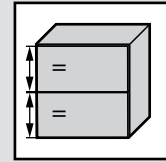
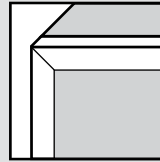

i

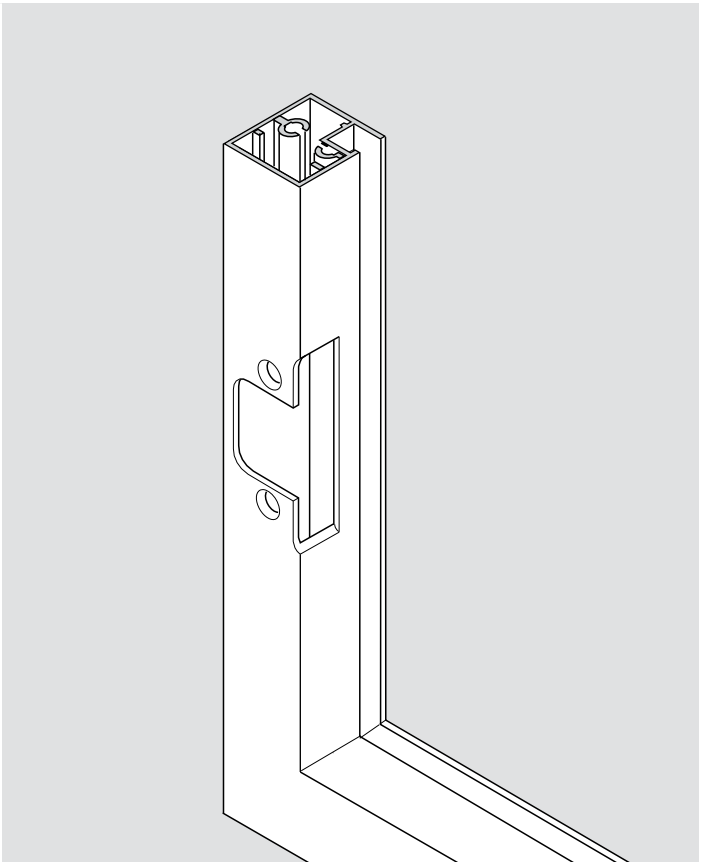
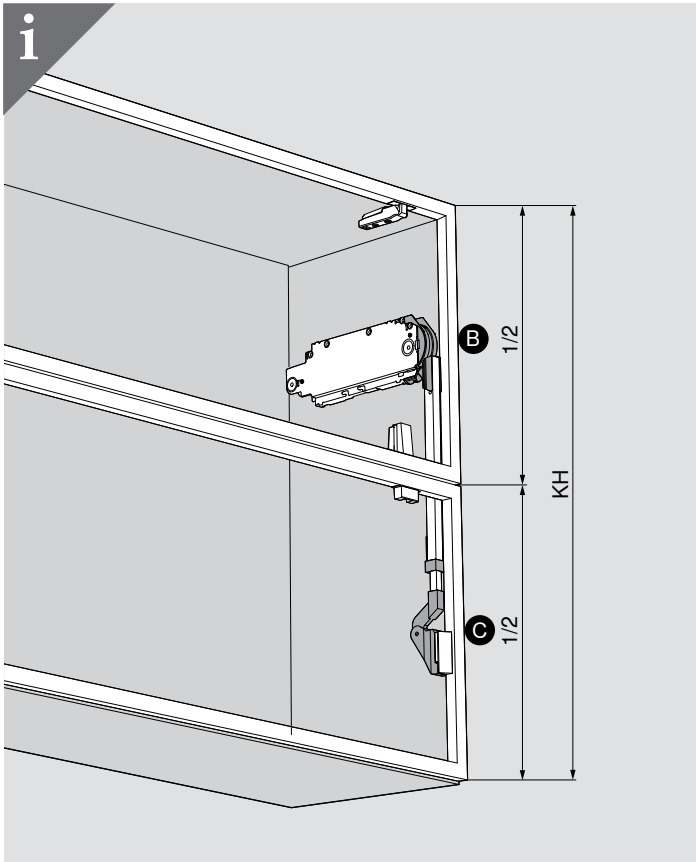

1

8 x  (3.5 x 11)

2 x

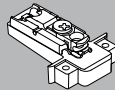

2 x

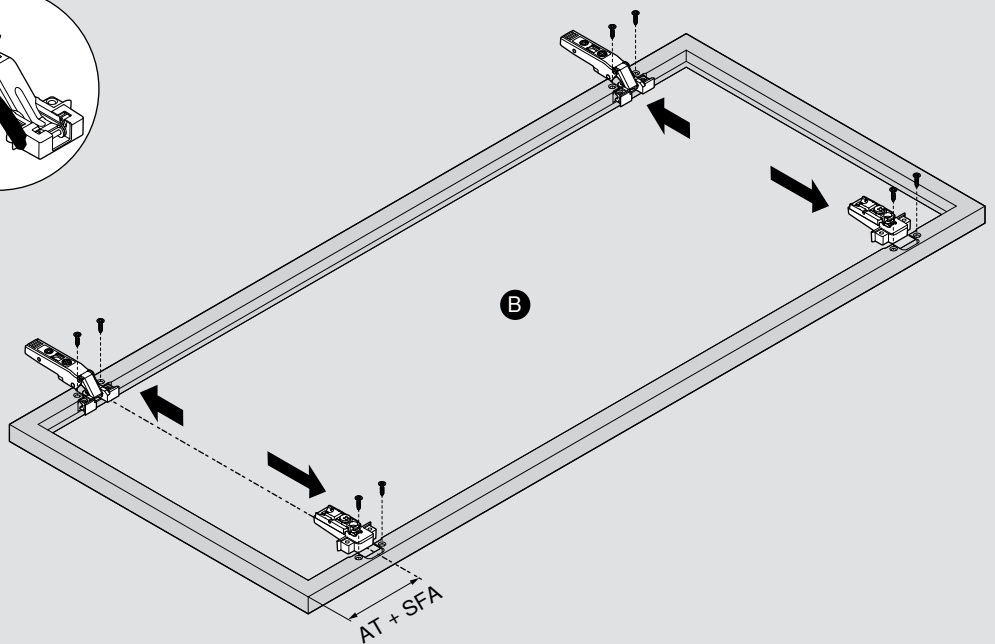
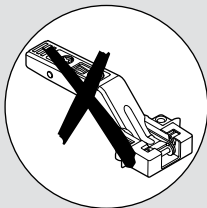
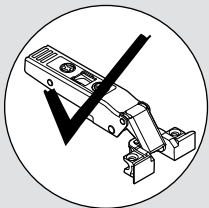
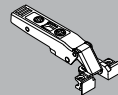

AVENTOS HF

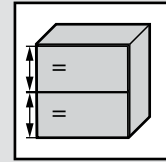
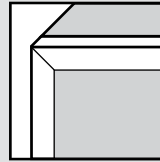

2

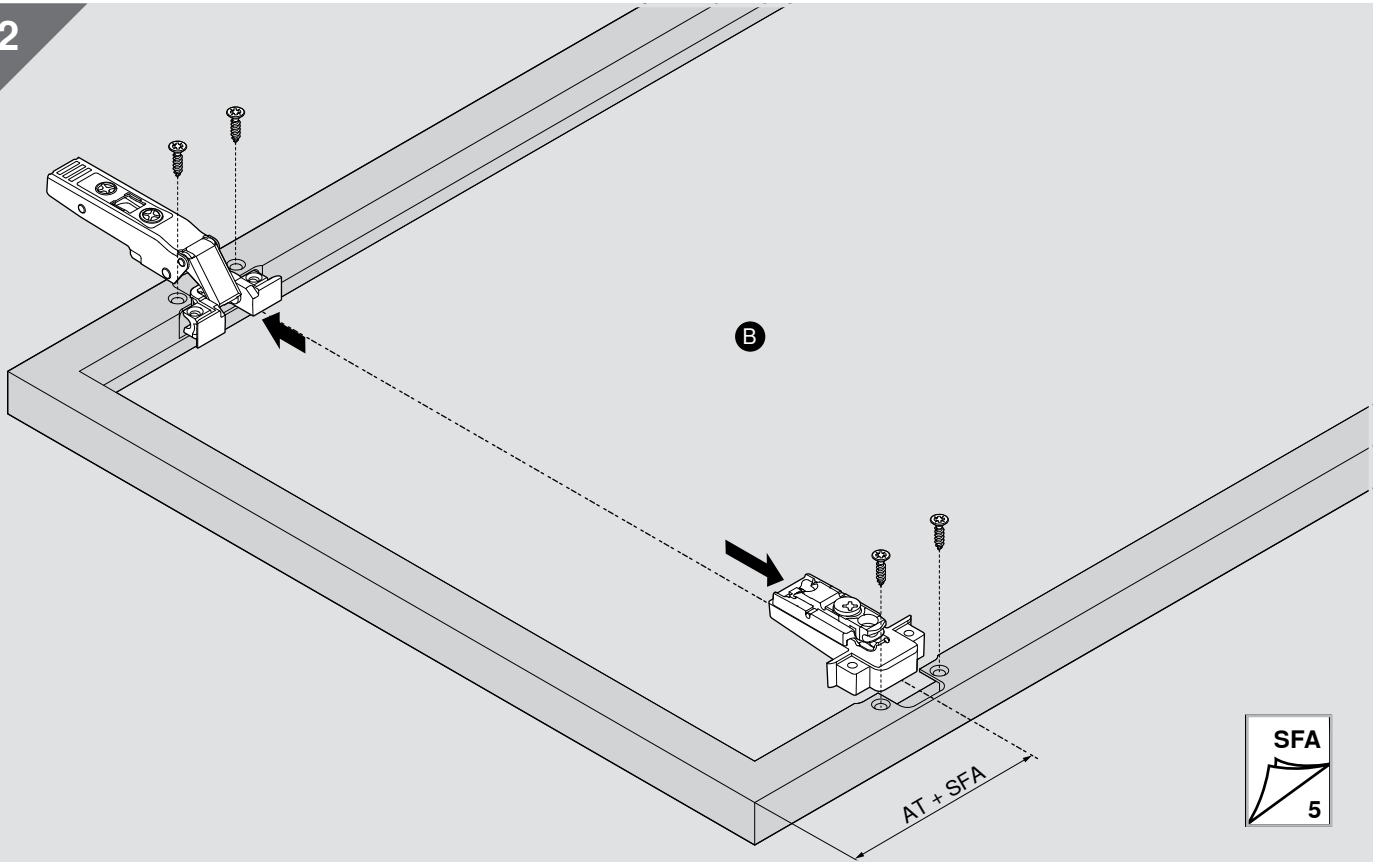

3

- 8 x (3.5 x 11)
- 2 x
- 2 x

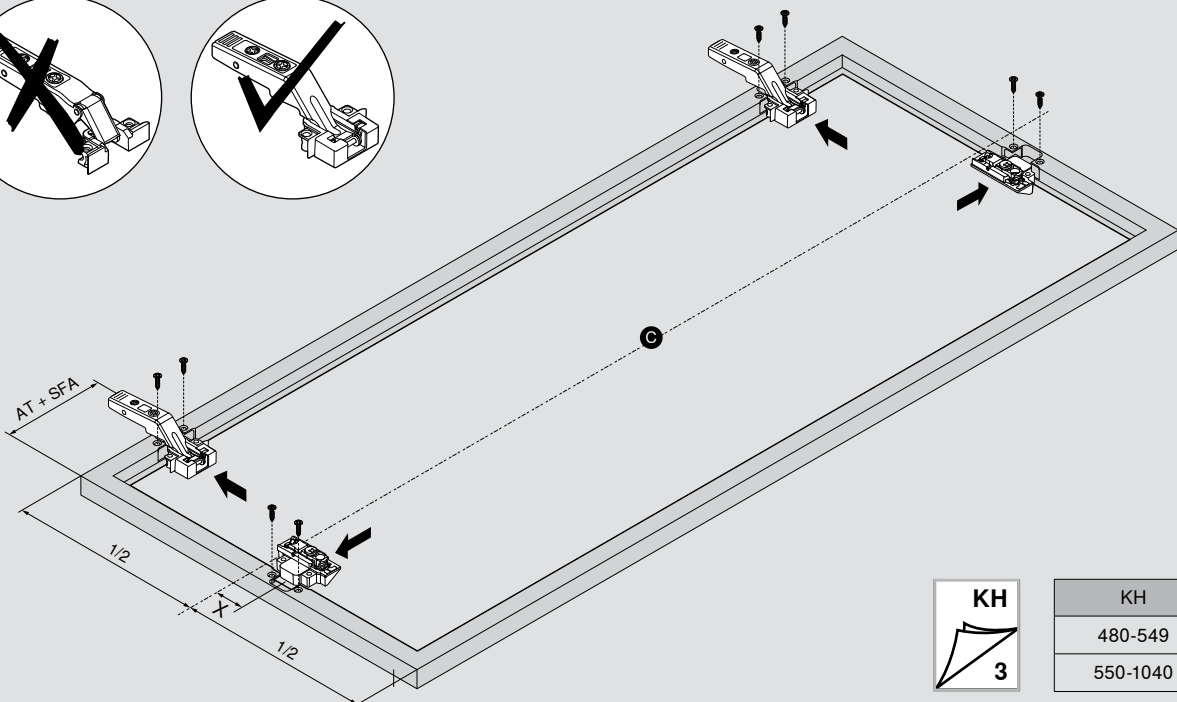
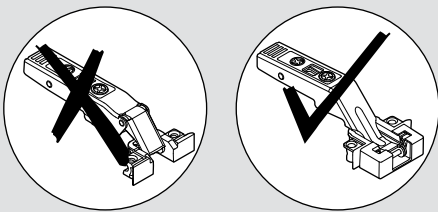

KH	x
480-549	54
550-1040	31

AVENTOS HF

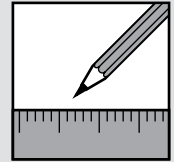
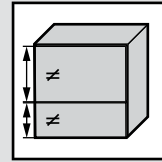

i

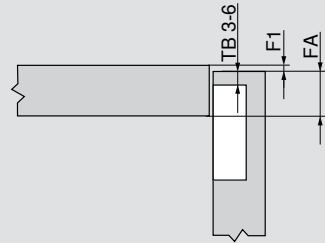
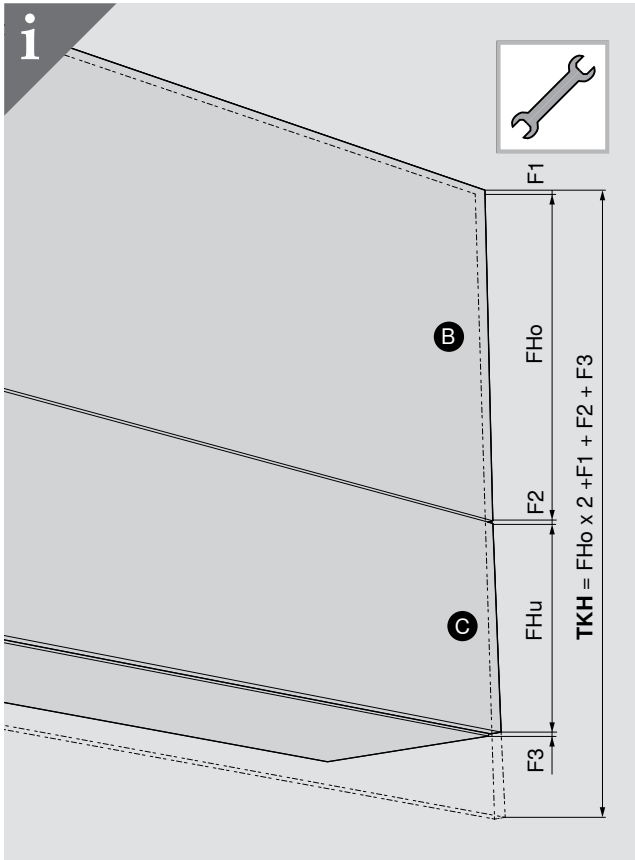

		FA																TB
		5	6	8	8	9	10	11	12	13	14	15	16	17				
MP	0											3	4	5	6			
	3							3	4	5	6							
	6				3	4	5	6										
	9	3	4	5	6													

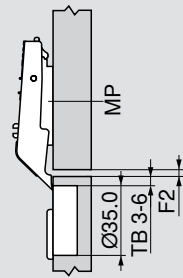

		F				TB
		3	4	5	6	
MP	0	6	5	4	3	
	3					
	6					
	9					

1

- 8 x (3.5 x 15)
- 2 x
- 2 x

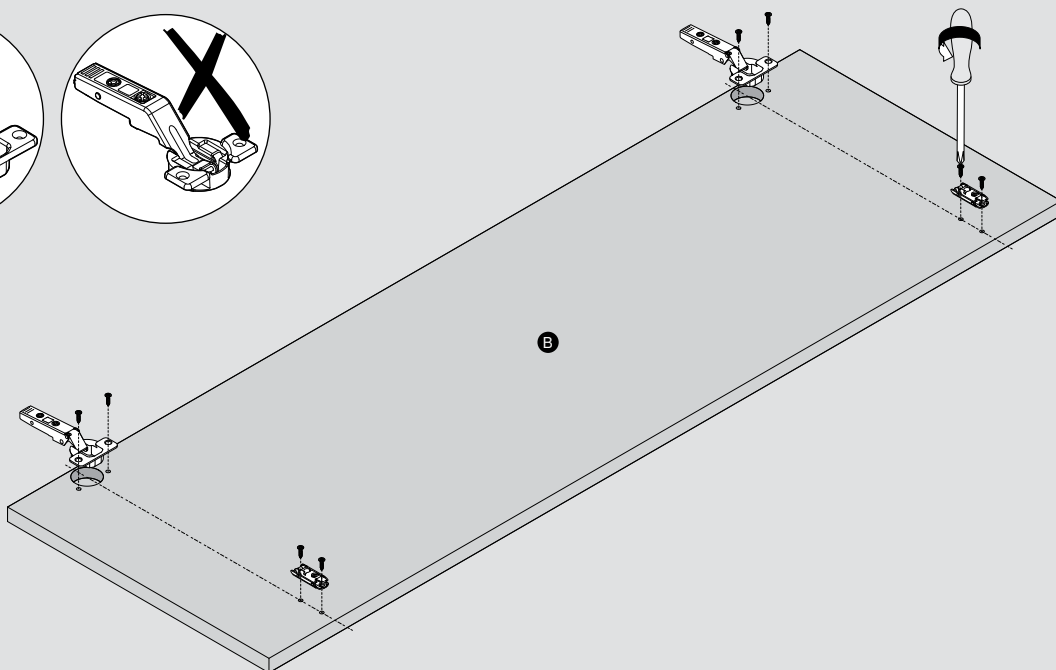
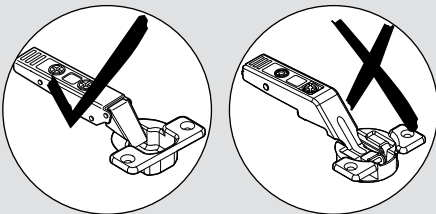

AVENTOS HF

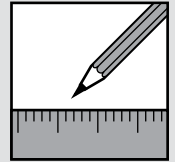
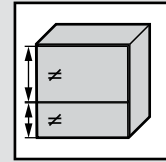

2

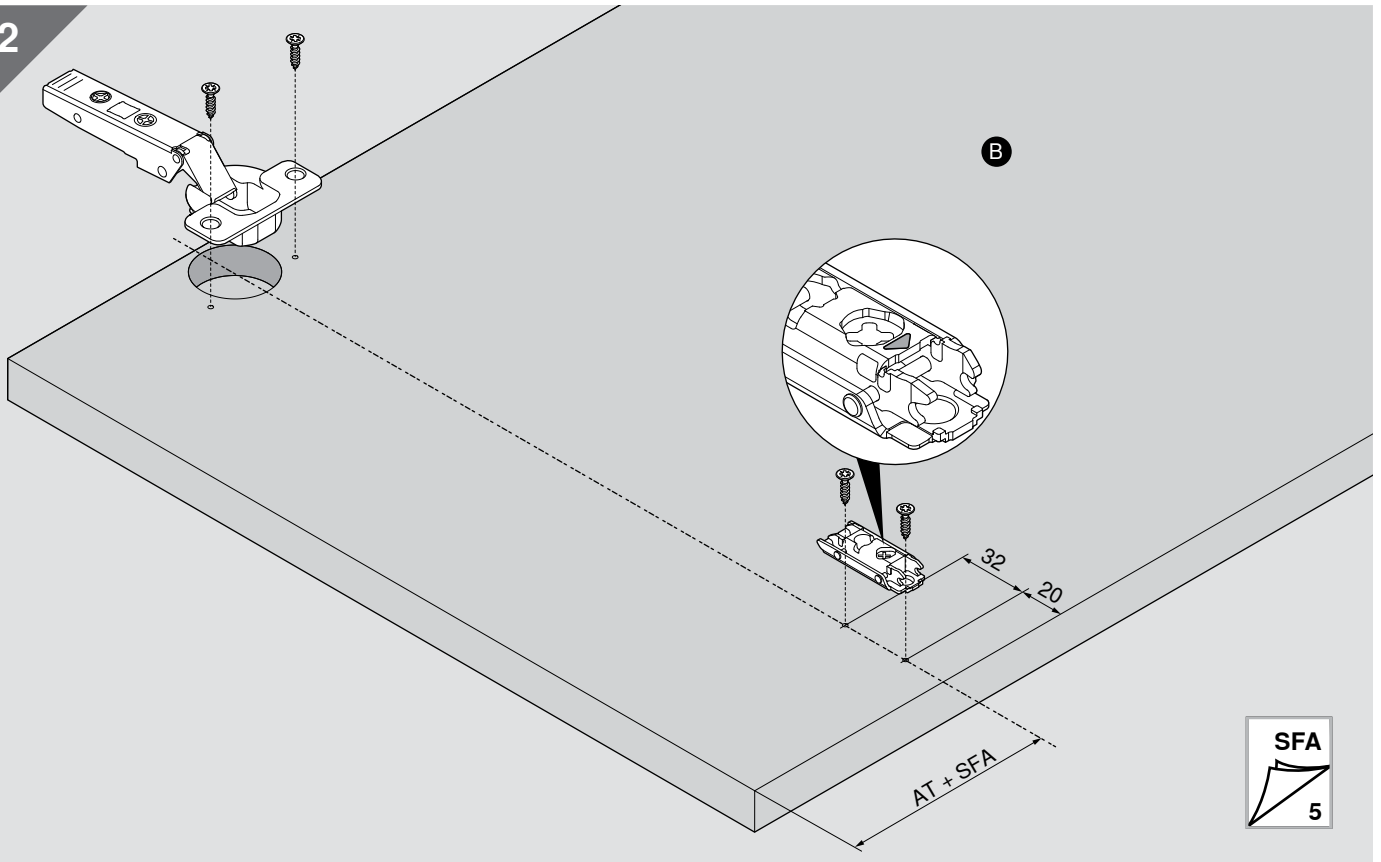

3

8 x (3.5 x 15) 2 x 2 x

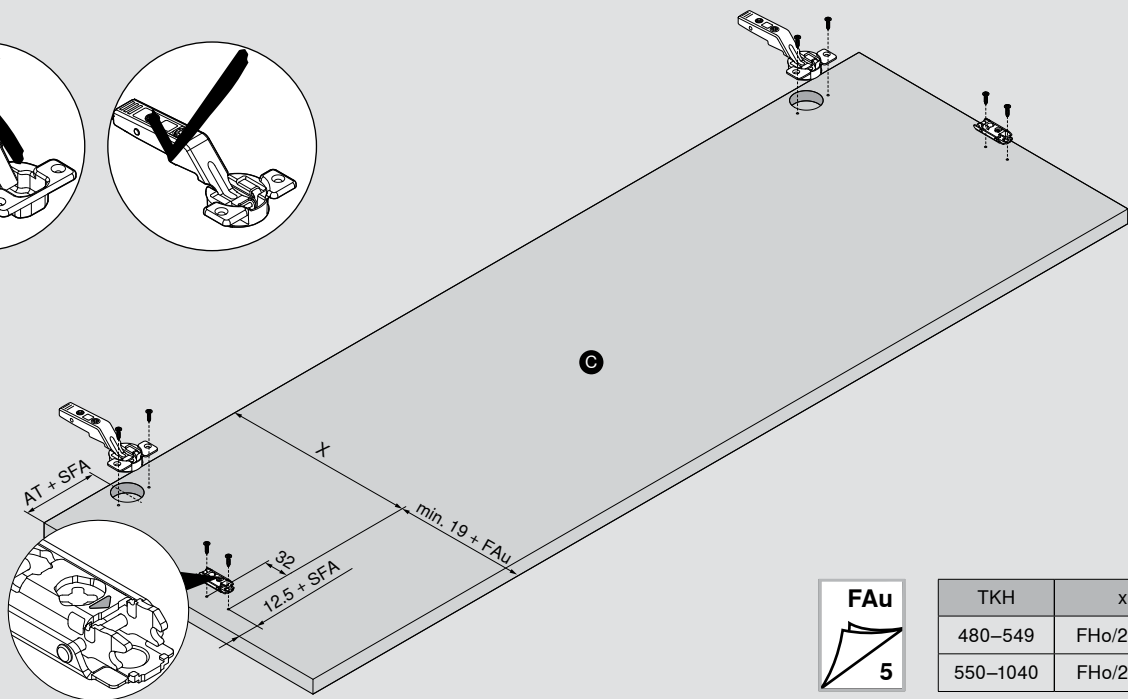
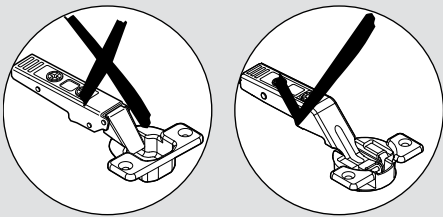

TKH	x
480-549	FHo/2 + 70
550-1040	FHo/2 + 47

AVENTOS HF

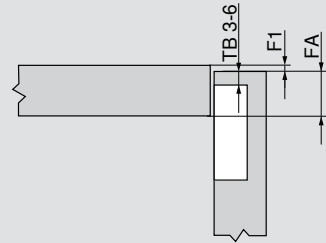
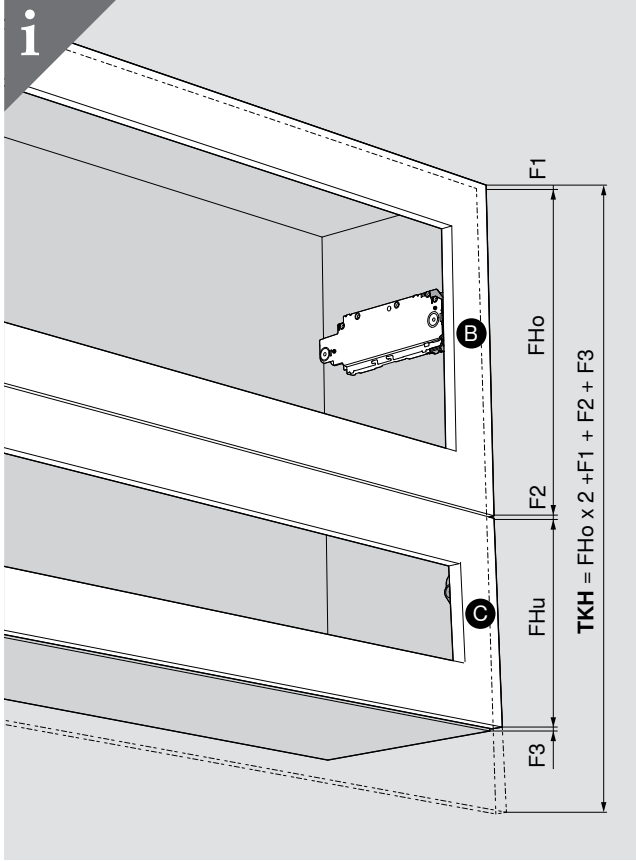
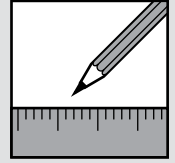
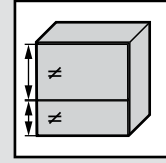
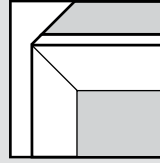

		FA															
		5	6	8	8	9	10	11	12	13	14	15	16	17			
MP	0											3	4	5	6	TB	
	3							3	4	5	6						
	6				3	4	5	6									
	9	3	4	5	6												

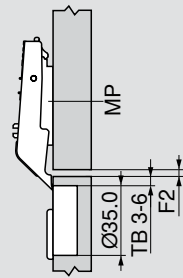

		F				
		3	4	5	6	
MP	0	6	5	4	3	TB
	3					
	6					
	9					

1

8 x (3.5 x 9.5)

2 x

2 x

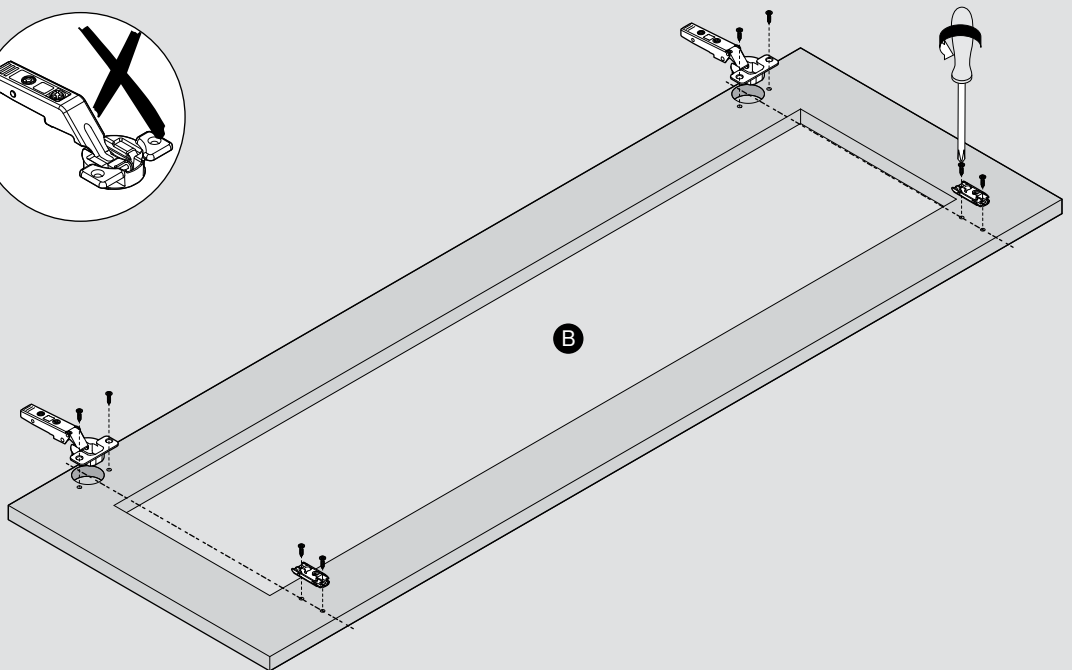
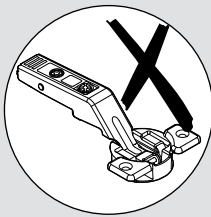
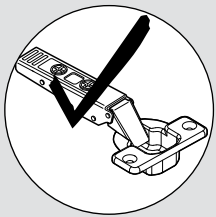

AVENTOS HF

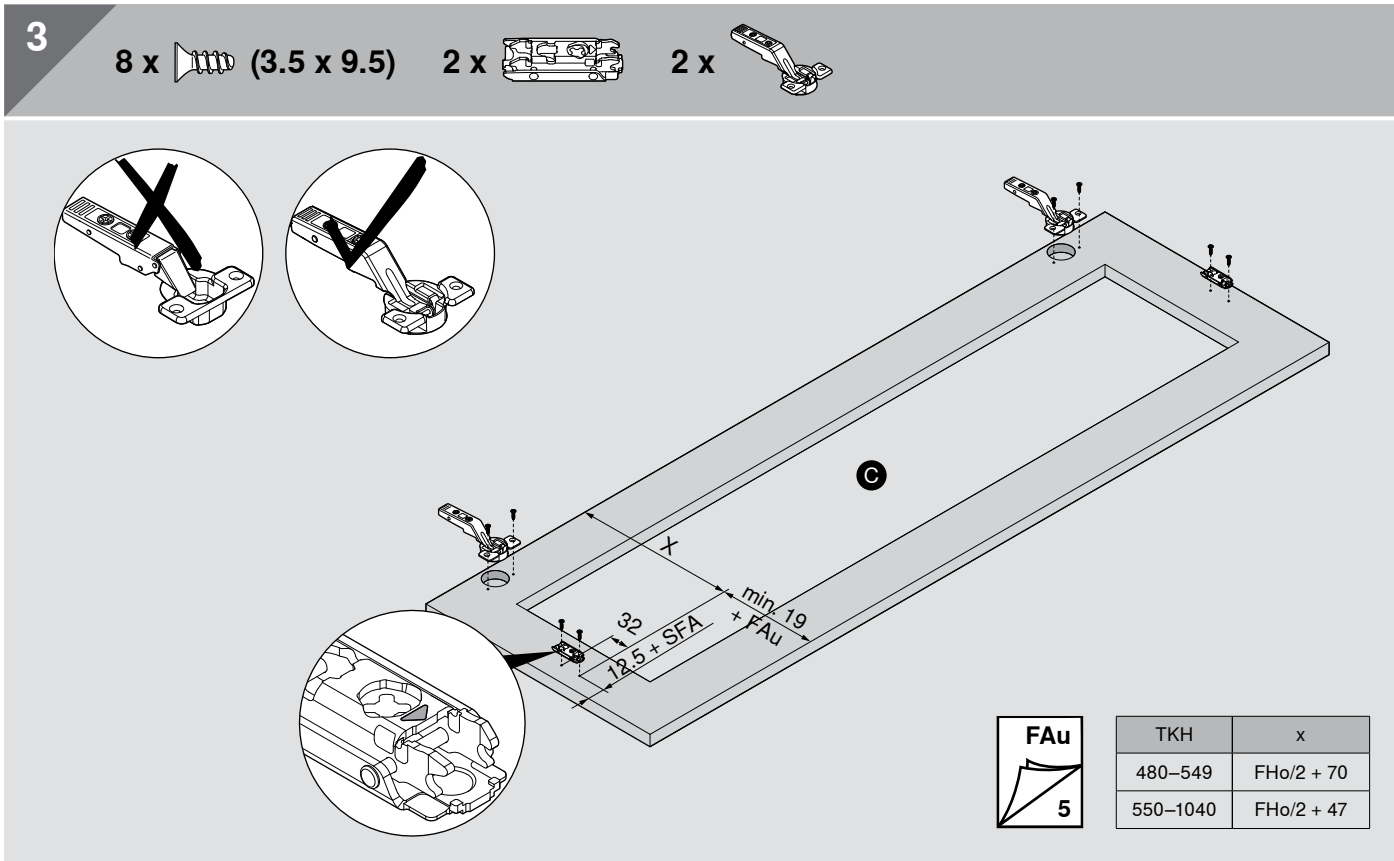
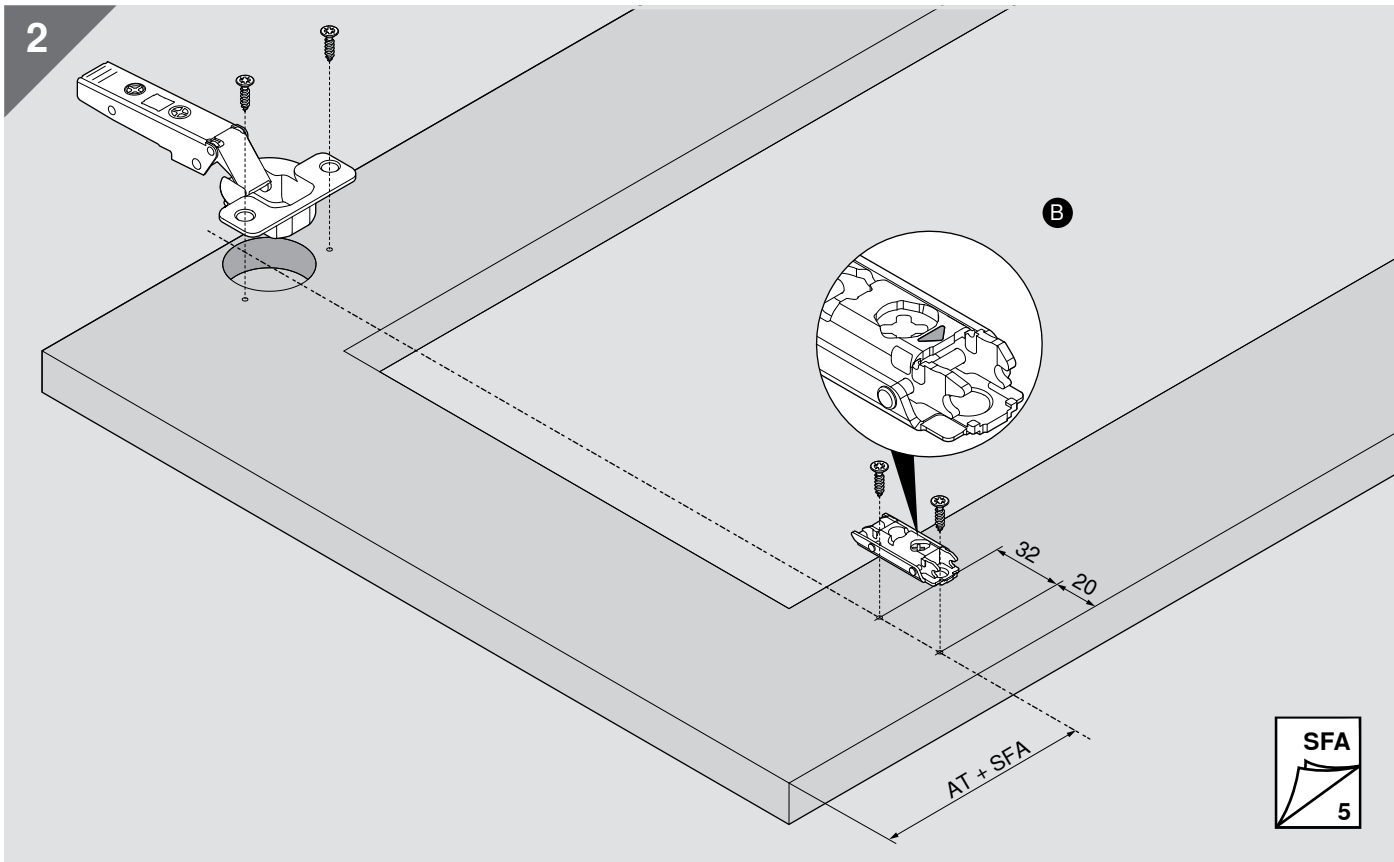
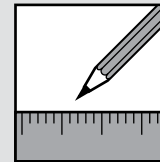
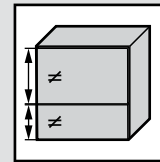
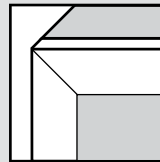

AVENTOS HF

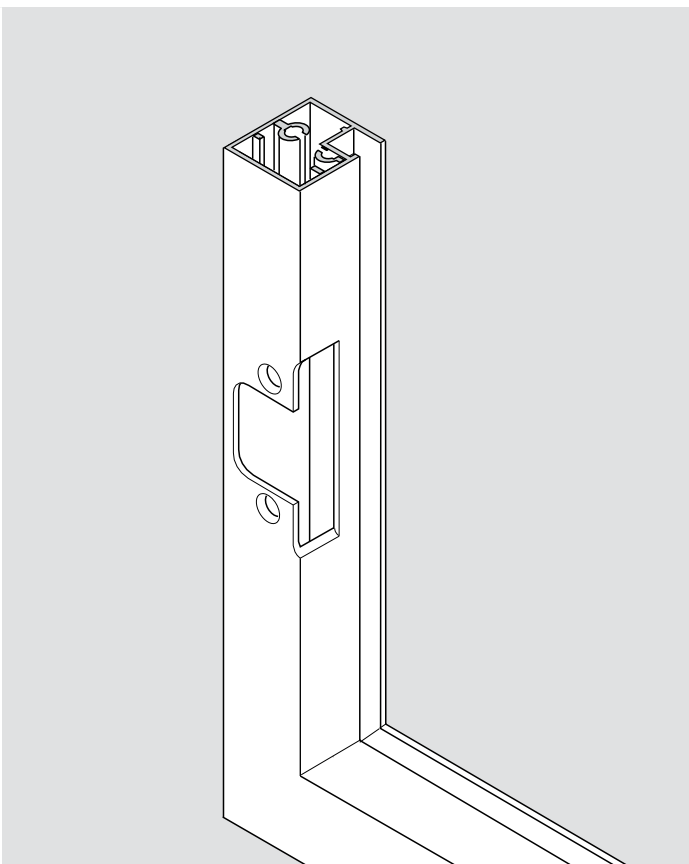
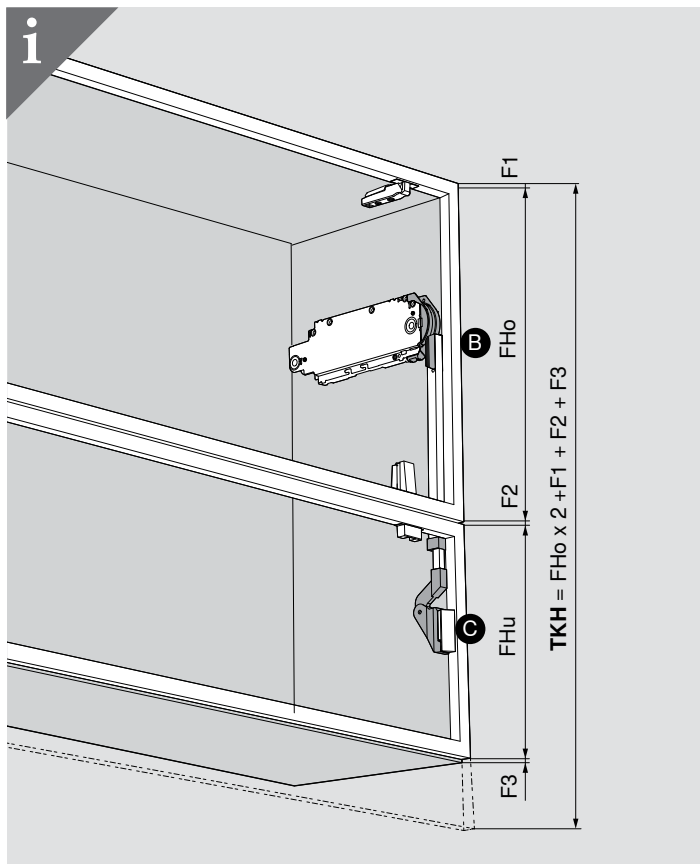
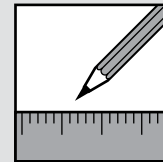
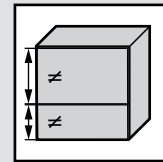
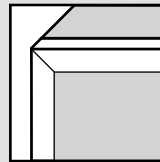

- 1**
- 8 x (3.5 x 11)
 - 2 x
 - 2 x

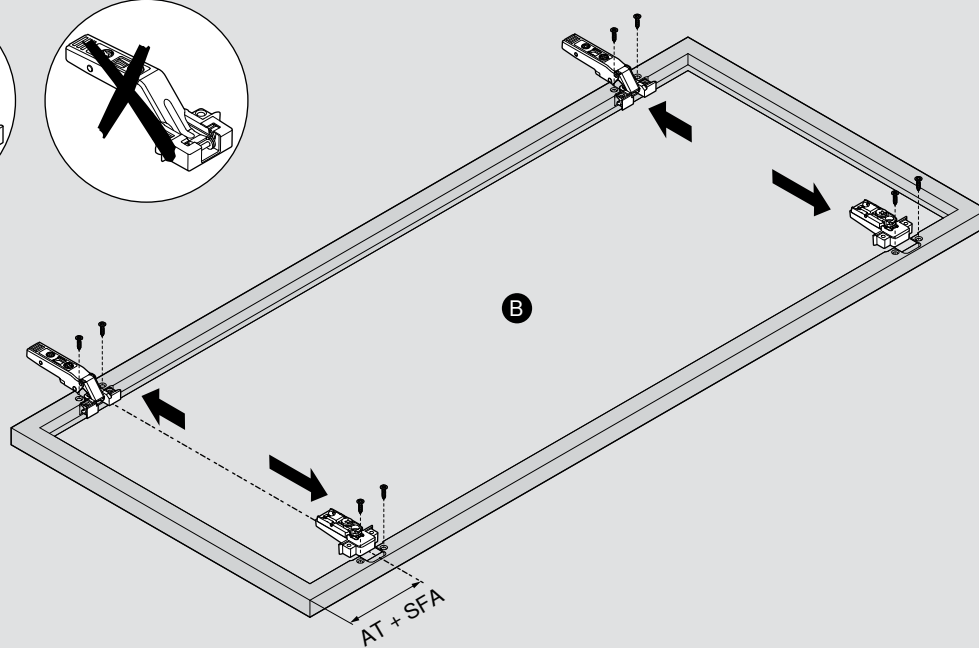
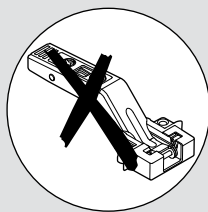
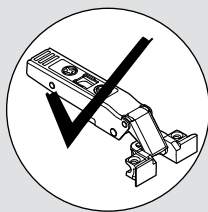

AVENTOS HF

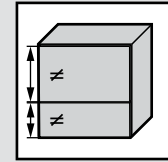
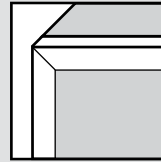

2

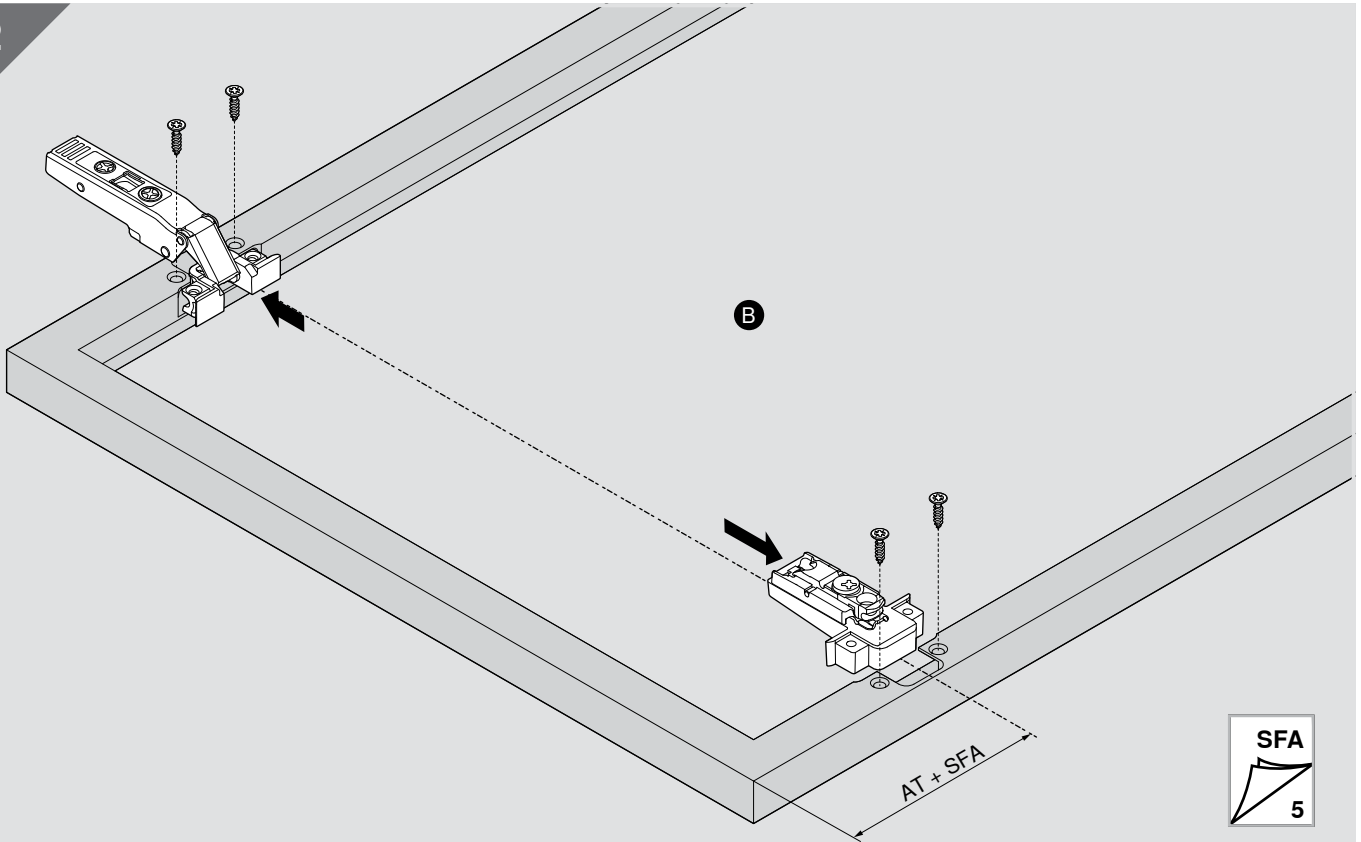

3

- 8 x (3.5 x 11) 2 x 2 x

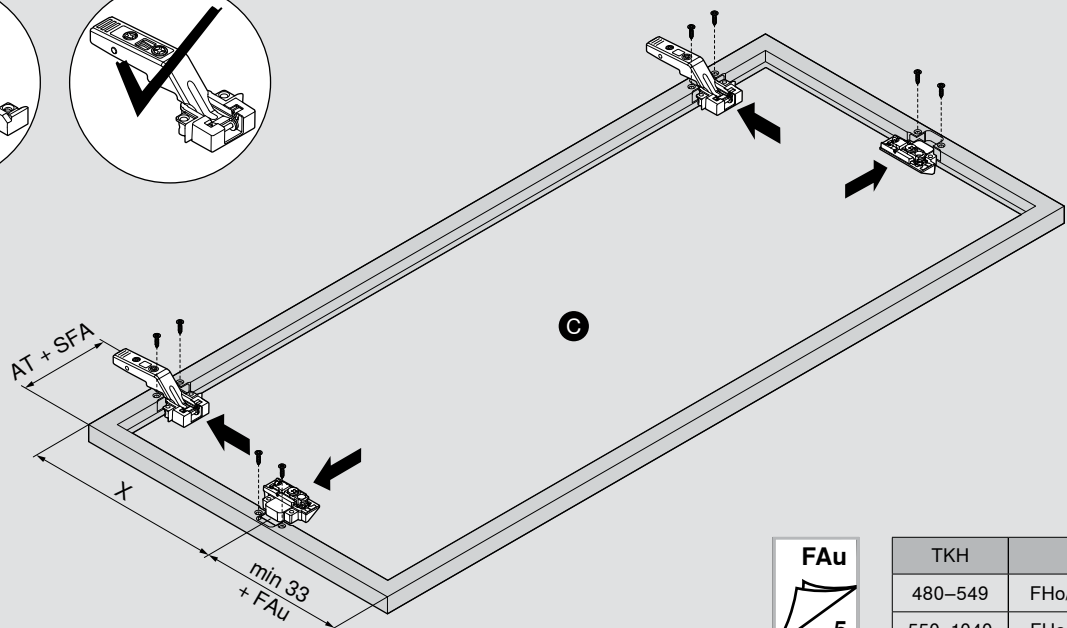
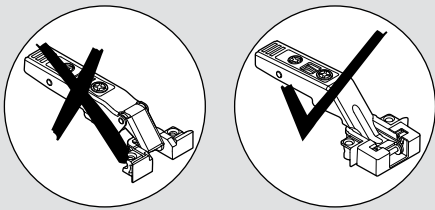

FAu	TKH	x
	480-549	FHo/2 + 54
550-1040	FHo/2 + 31	

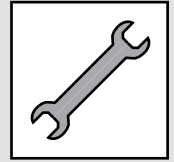

WARNING | WARNING | AVERTISSEMENT | AVVERTENZA |
 ADVERTENCIA | OSTRZEŻENIE | ВНИМАНИЕ | 警告

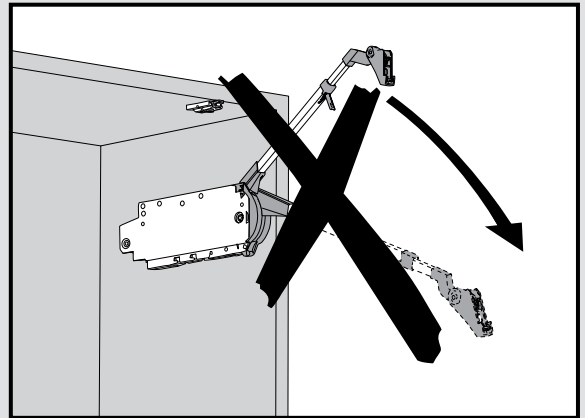
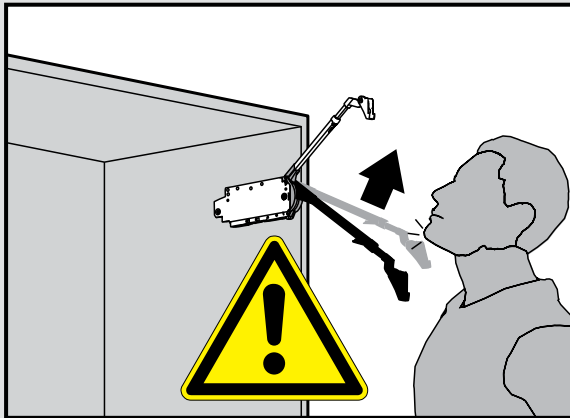

Verletzungsgefahr durch hochspringenden Teleskophebel!
 Risk of injury by spring-loaded telescopic arm!
 Risque de blessure en cas de relevage brusque du bras télescopique !
 Pericolo di lesioni a causa del possibile scatto verso l'alto della leva telescopica!
 Peligro de lesiones por salto de la palanca telescópica.
 Niebezpieczeństwo zranienia przez gwałtownie unoszący się podnośnik teleskopowy!
 Существует опасность получения травмы при резком подъеме телескопического рычага!
 アームが跳ね上がってケガをする可能性があります。

Teleskophebel nicht nach unten drücken, sondern entfernen.
 Do not push telescopic arm down without door attached but remove.
 Ne pas pousser le bras télescopique vers le bas, mais le retirer.
 Non spingere la leva telescopica verso il basso, altrimenti rimuoverlo.
 No apretar la palanca telescópica hacia abajo, si no retirarlo.
 Nie opuszczać podnośnika teleskopowego, lecz wyjąć.
 Не опускайте рычаги. В случае необходимости их следует снимать.
 アームを外す時は下に押さないでください。

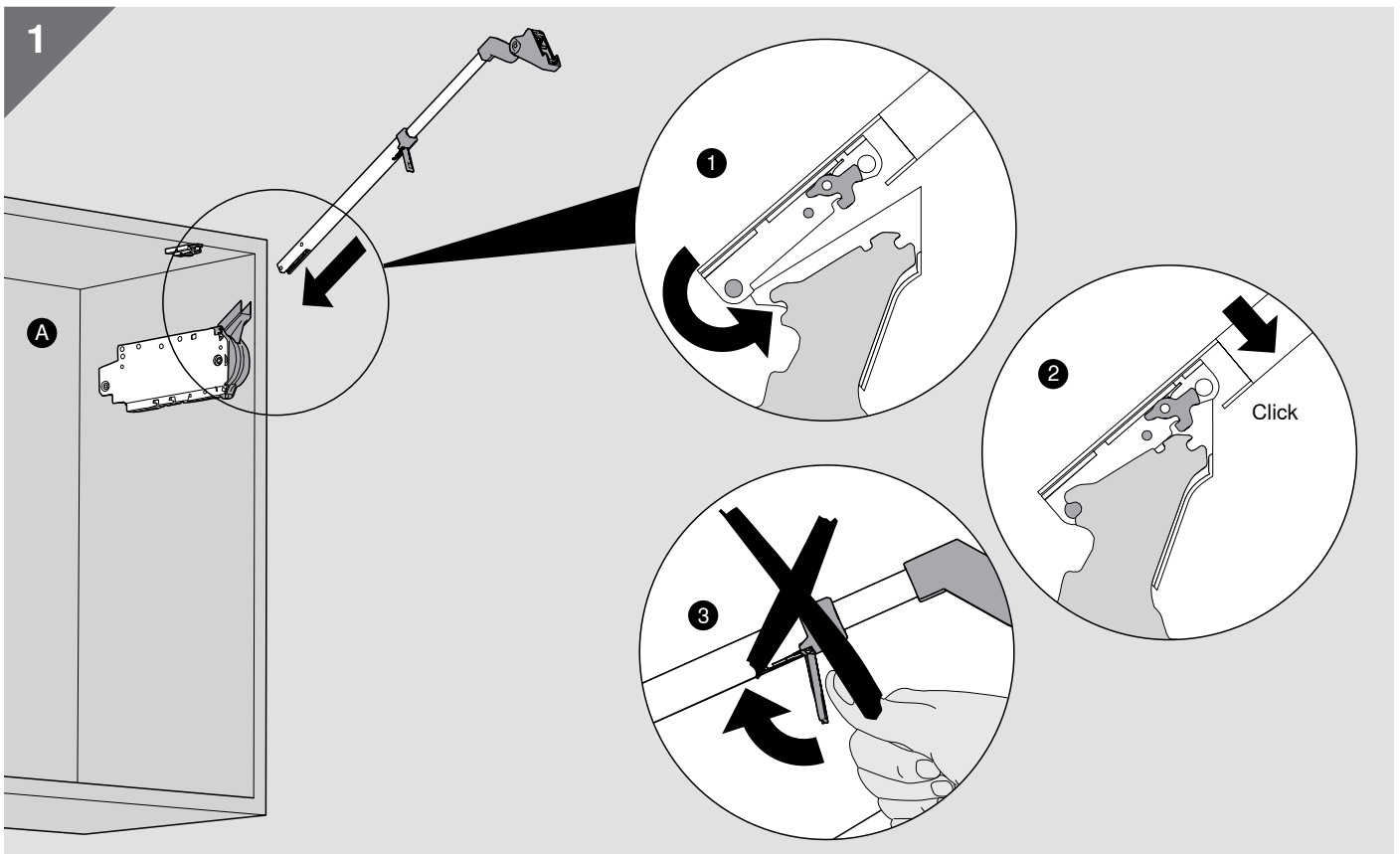

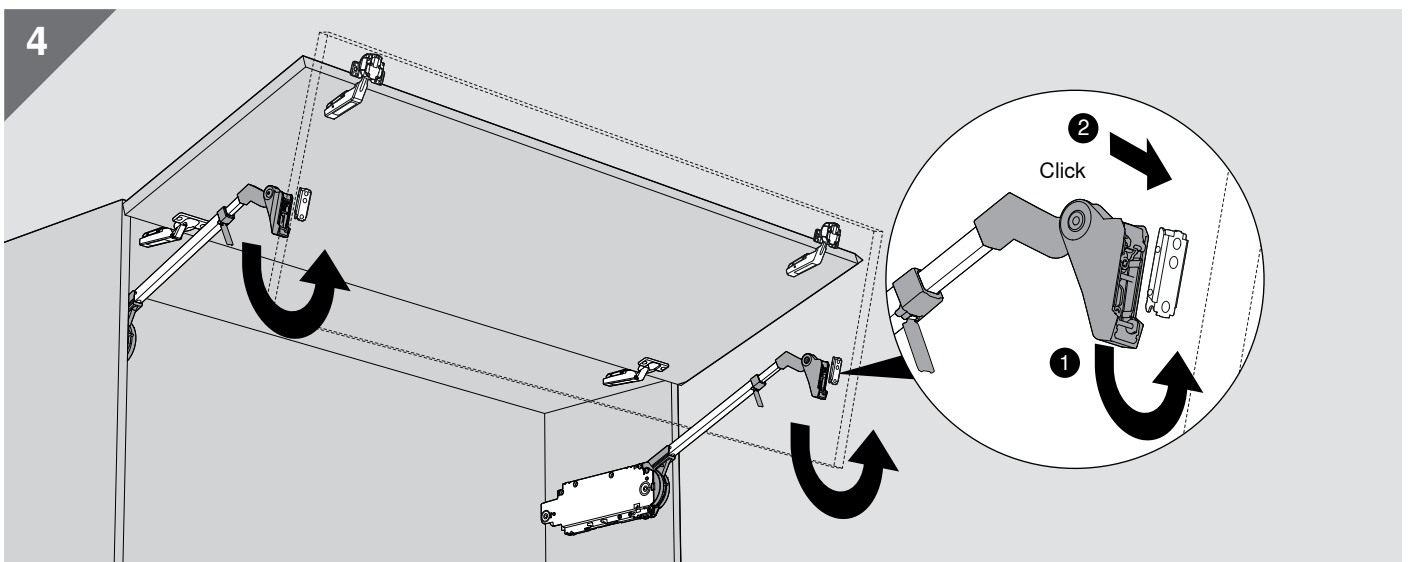
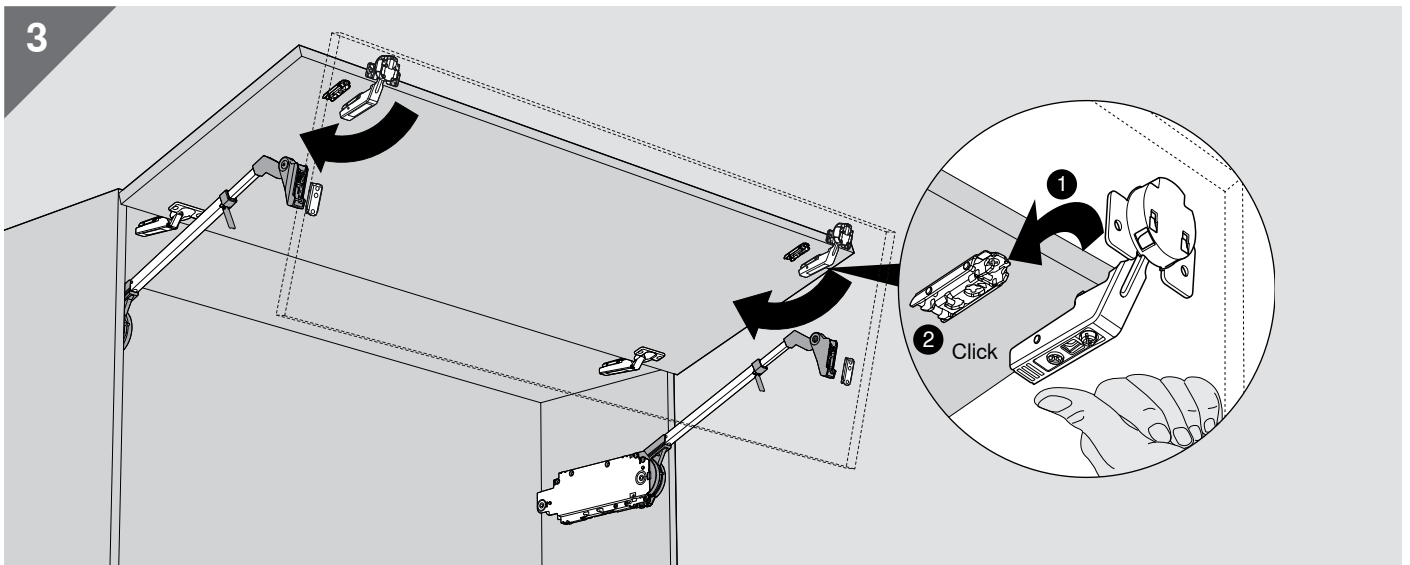
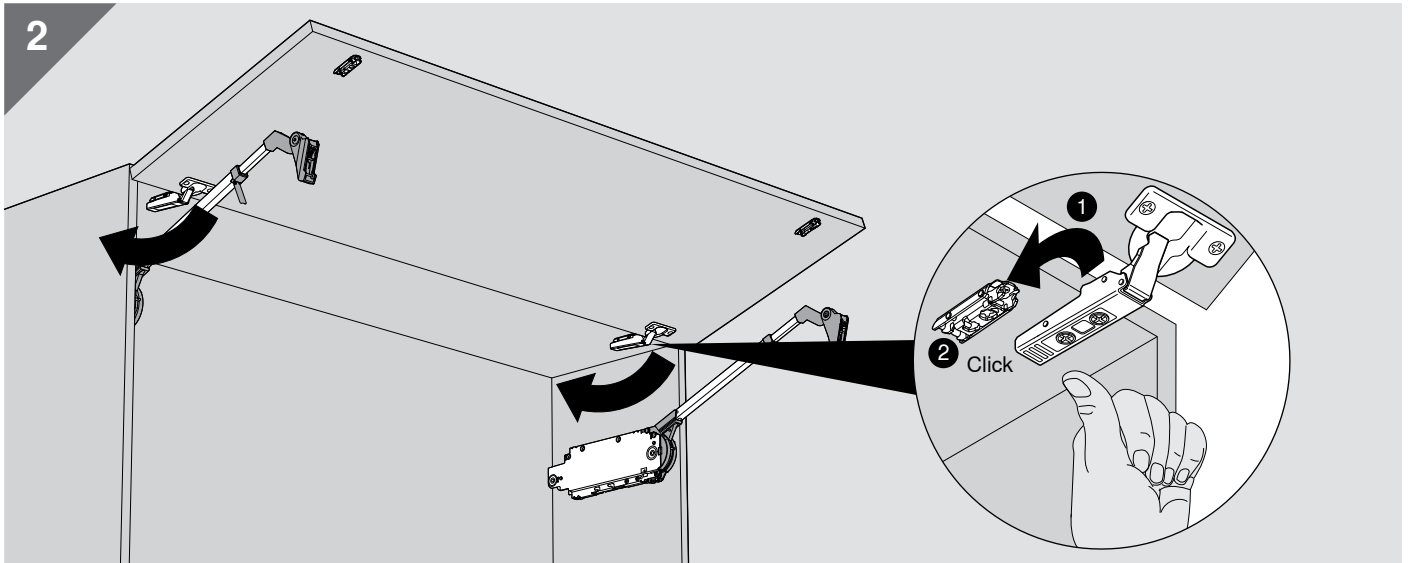
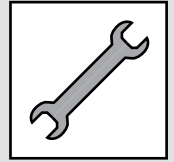

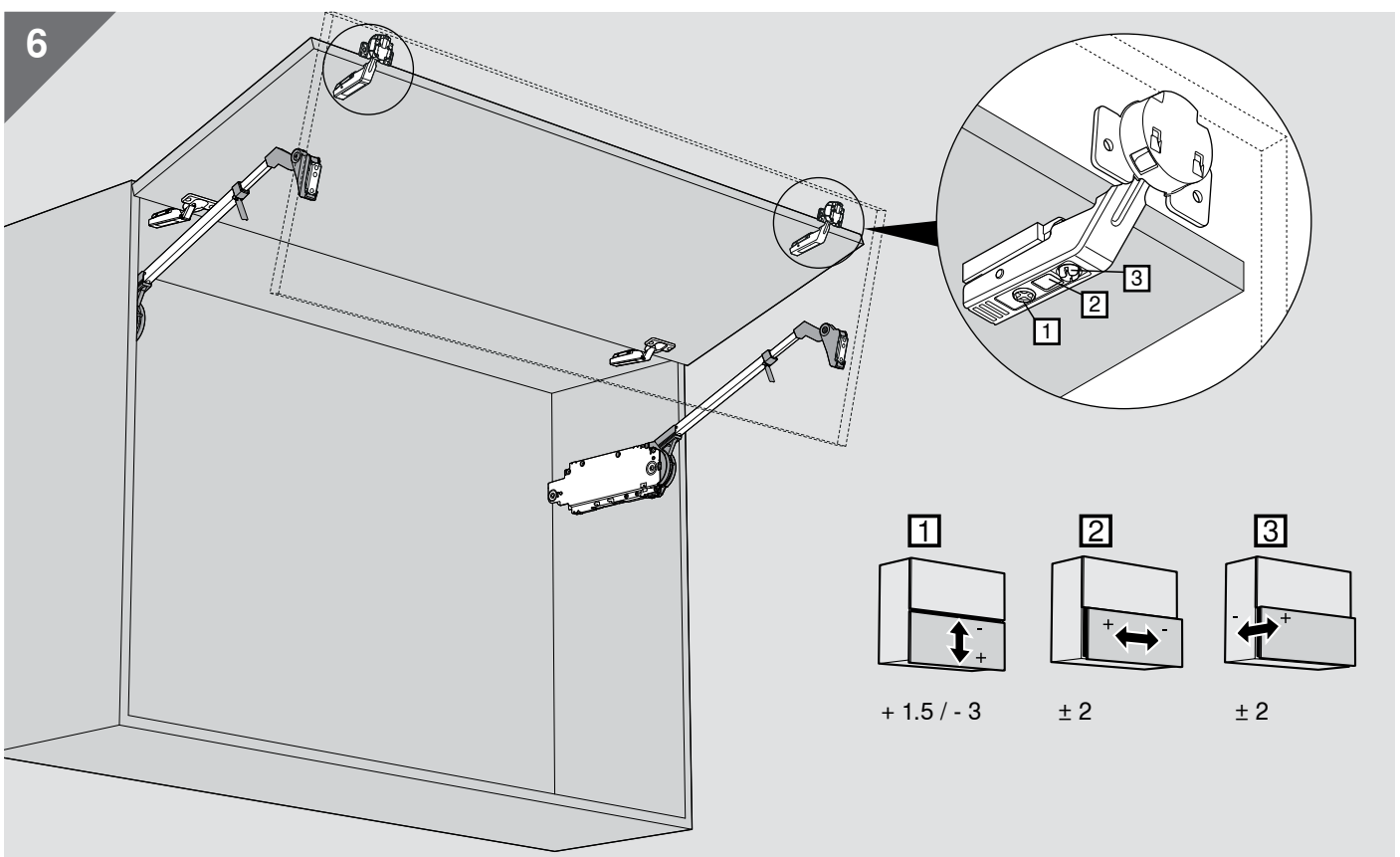
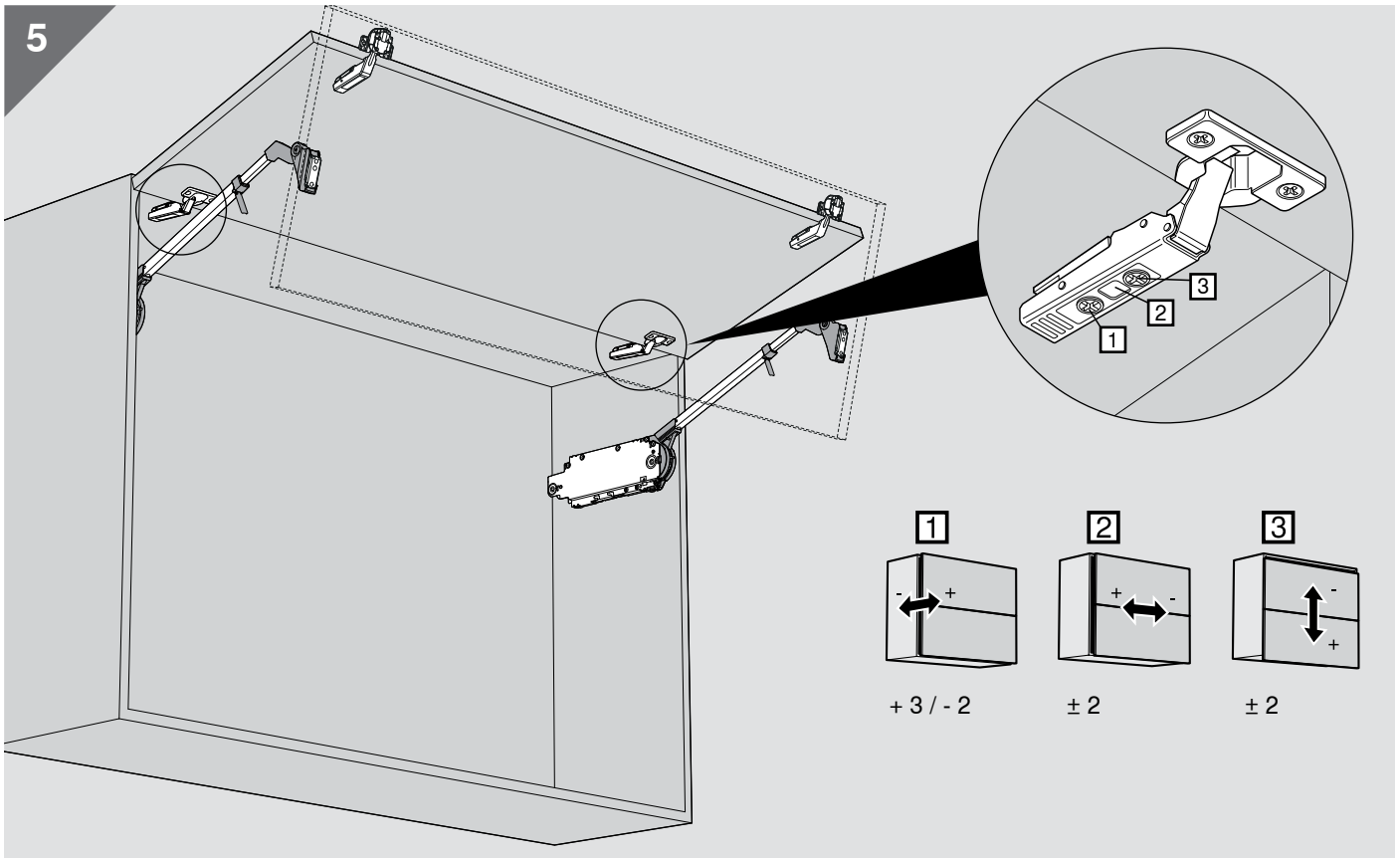
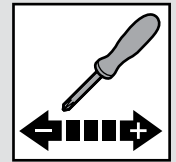

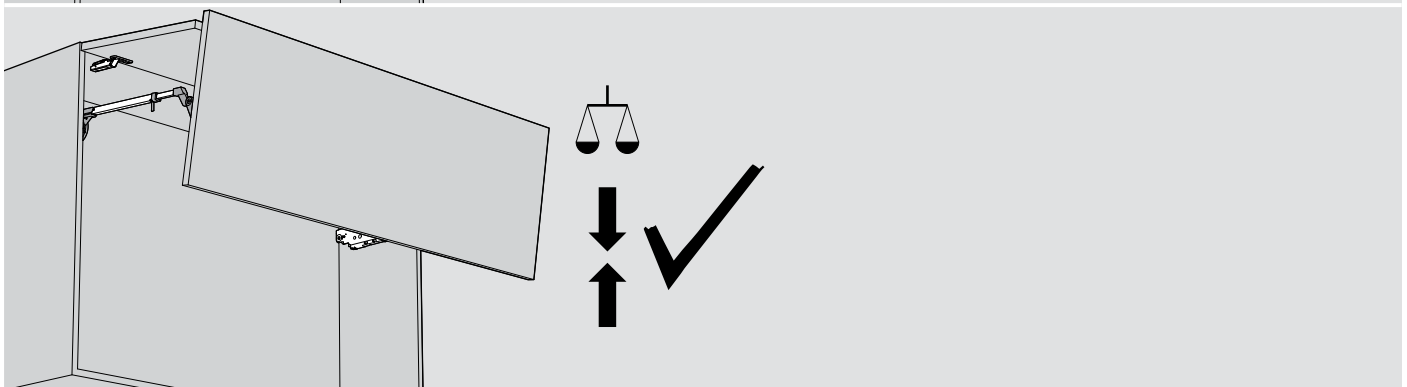
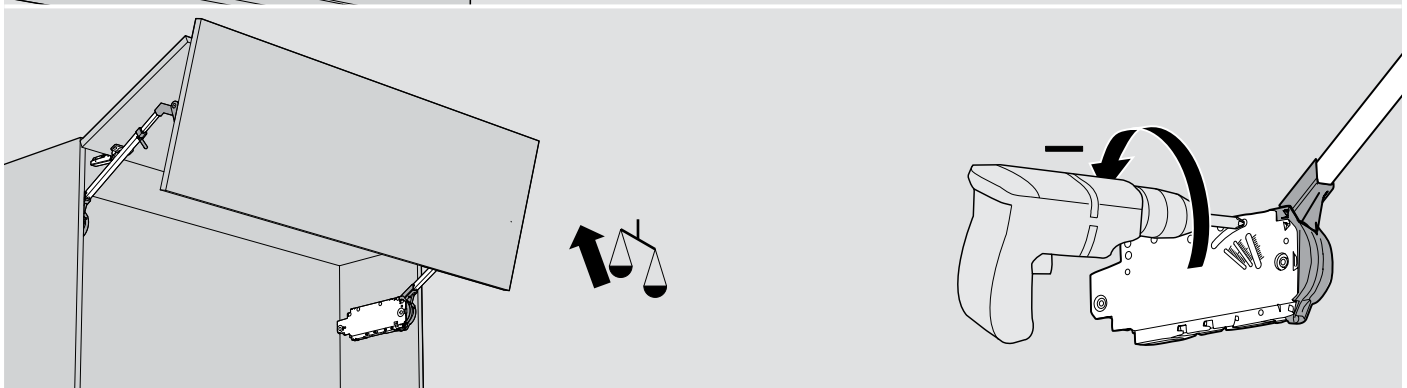
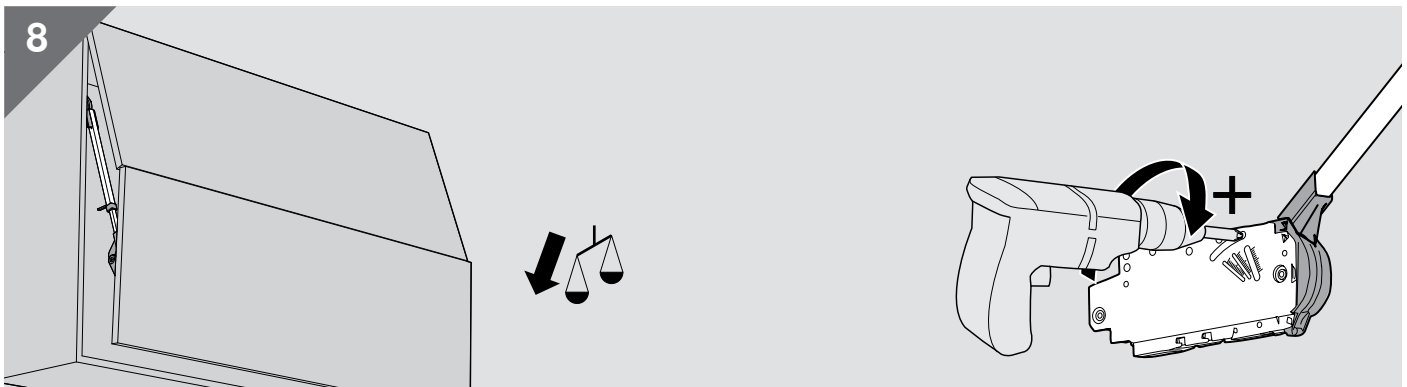
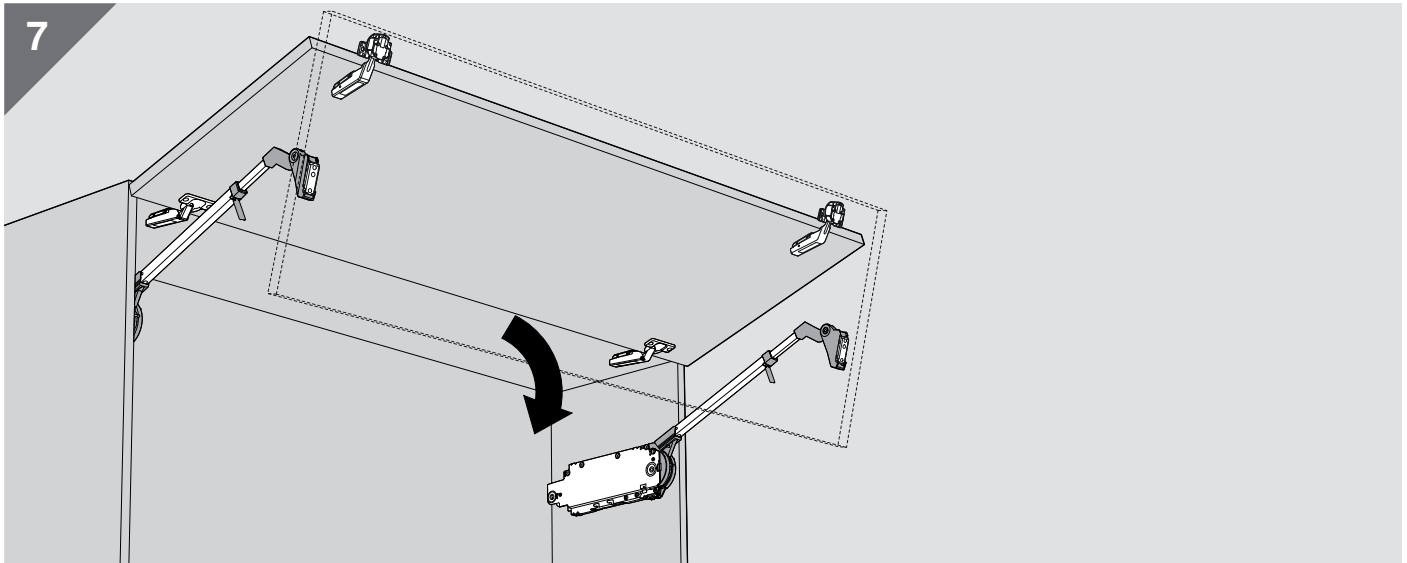
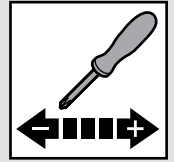

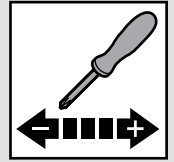

9

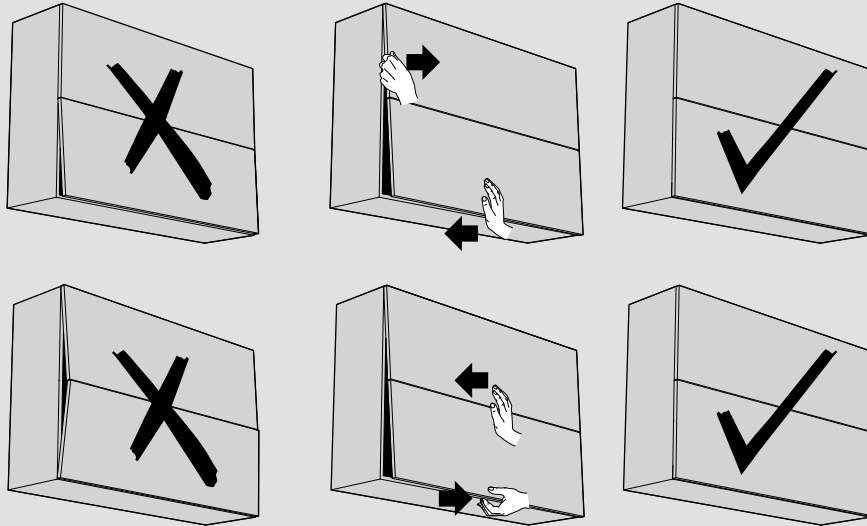

10

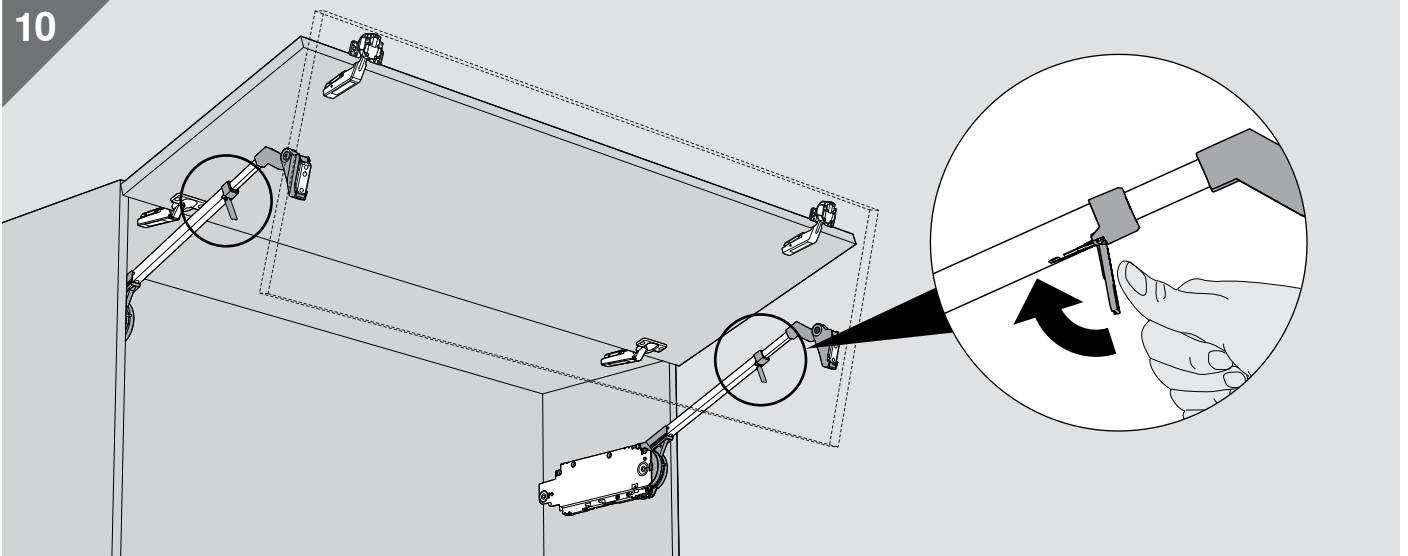

11

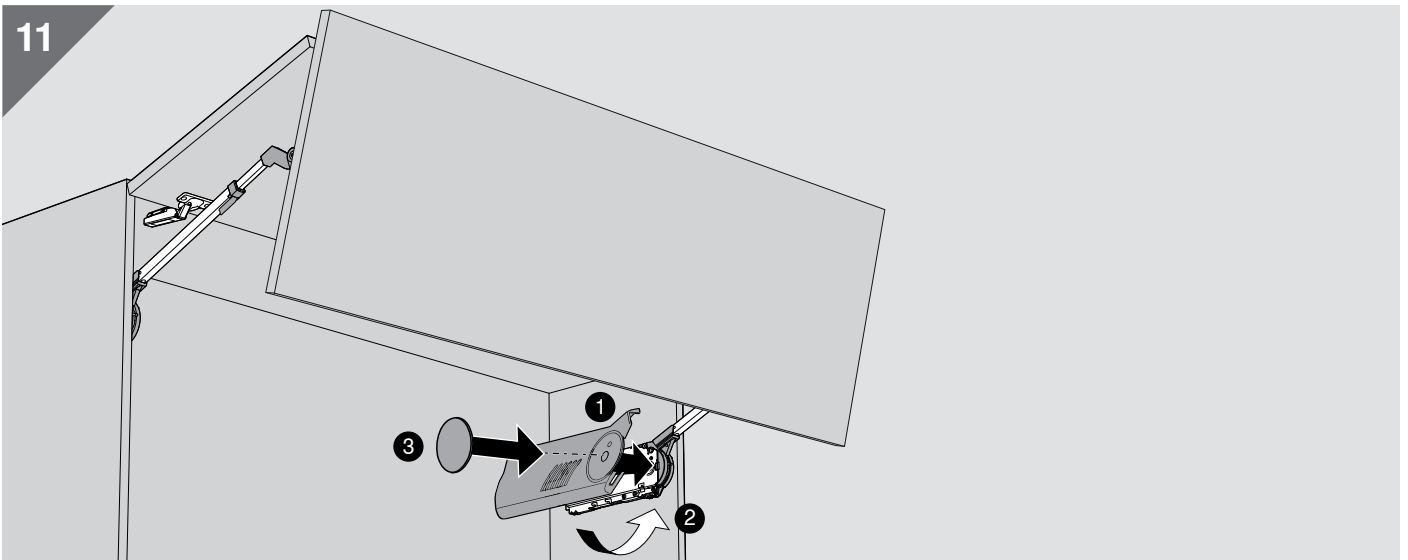

AVENTOS HF

 **blum**

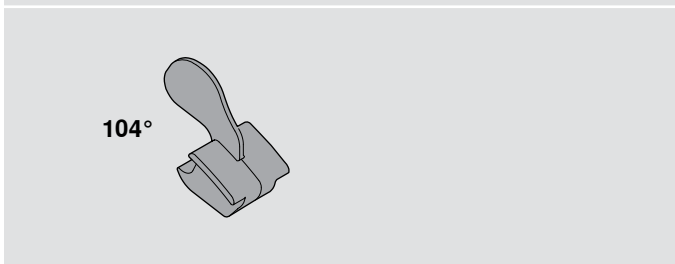
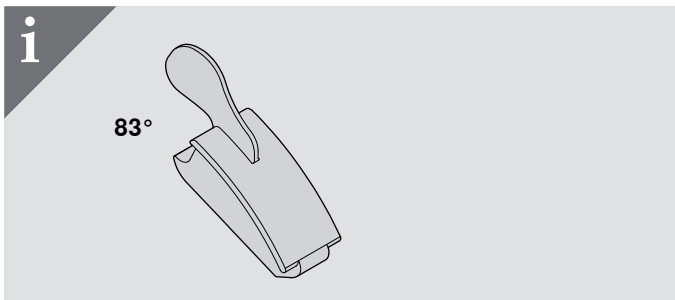
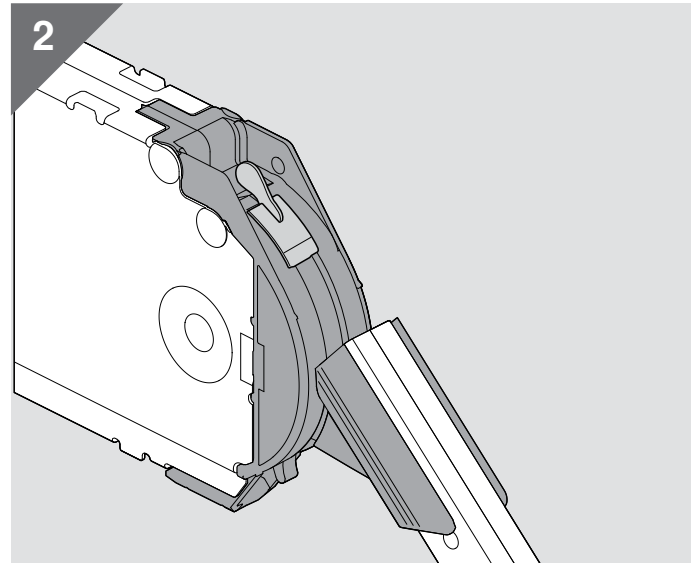
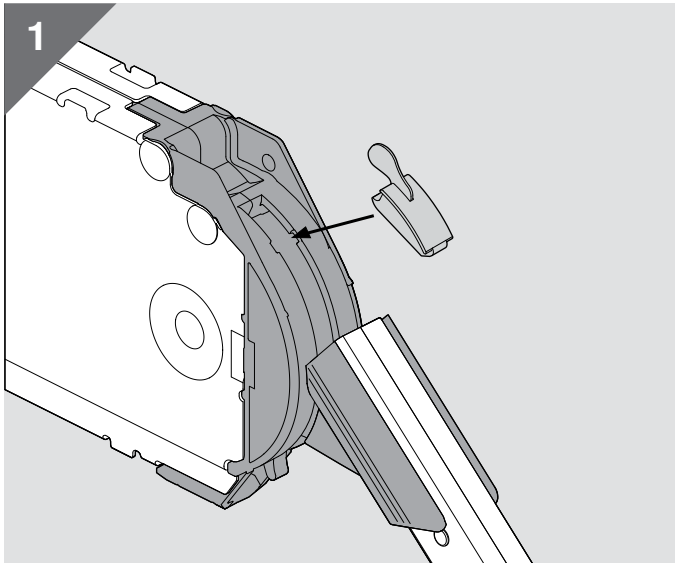
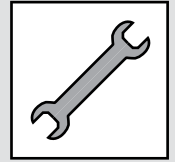
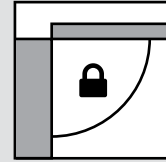

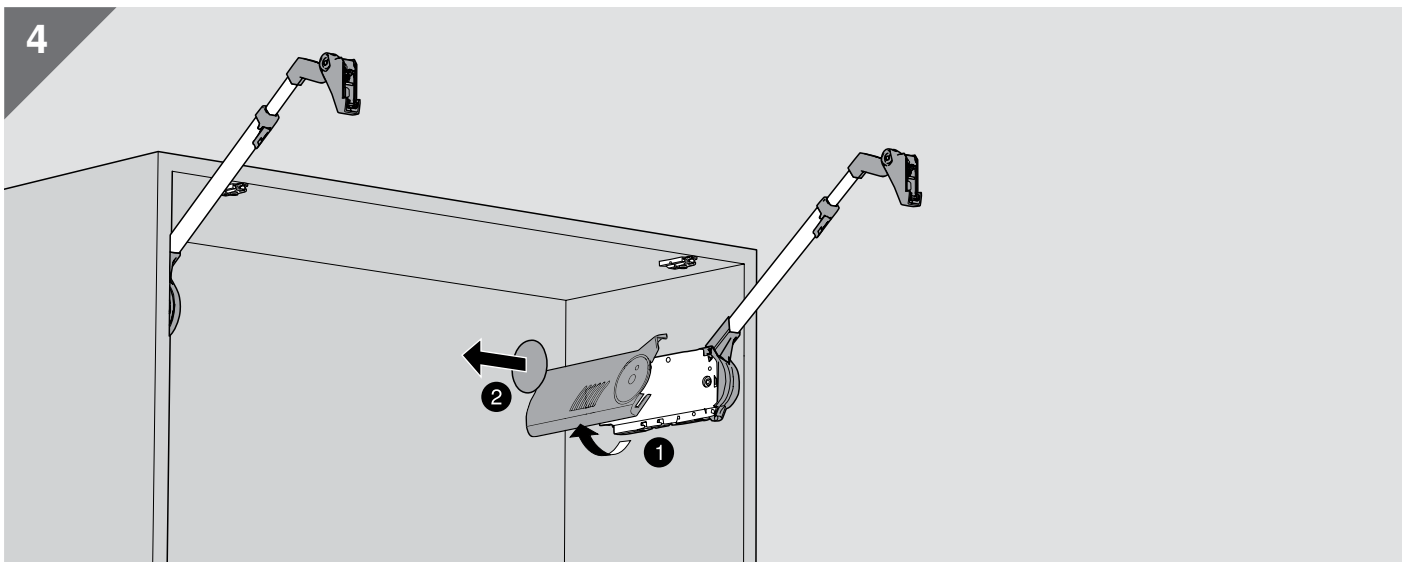
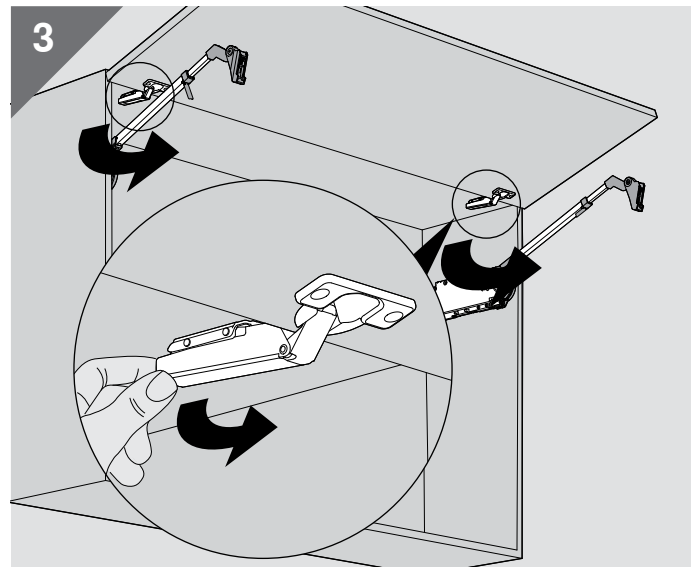
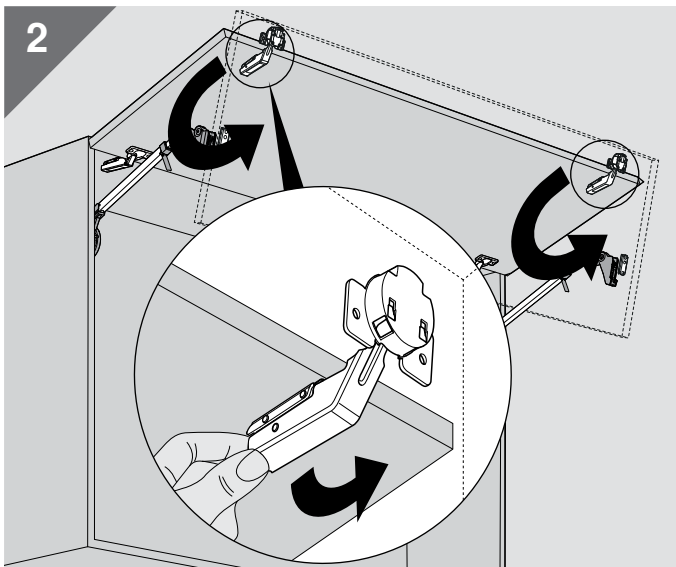
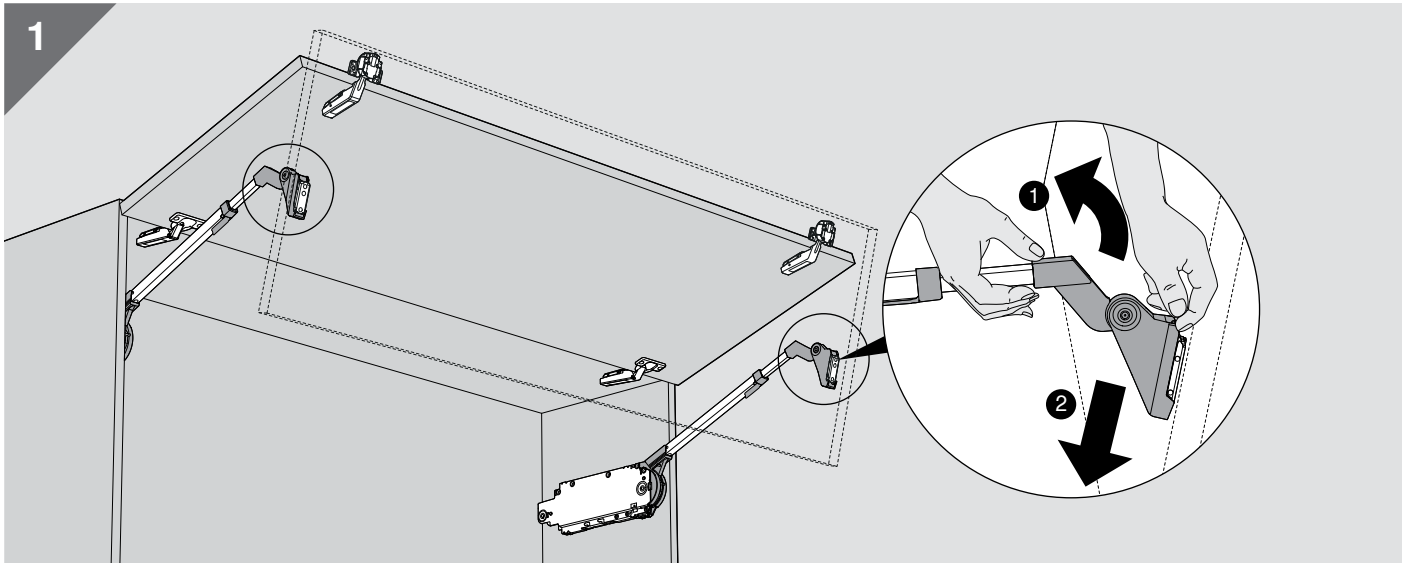

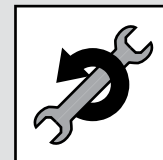

WARNING | WARNING | AVERTISSEMENT | AVVERTENZA |
 ADVERTENCIA | OSTRZEŻENIE | ВНИМАНИЕ | 警告

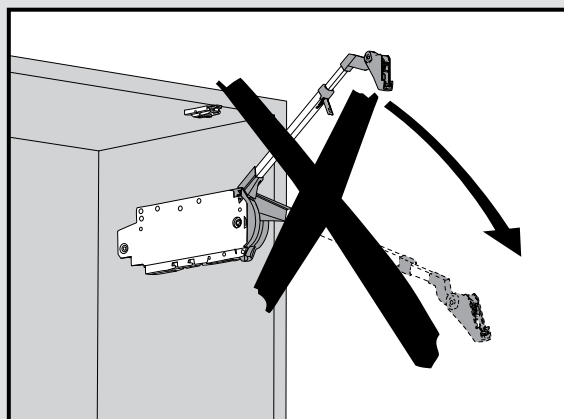
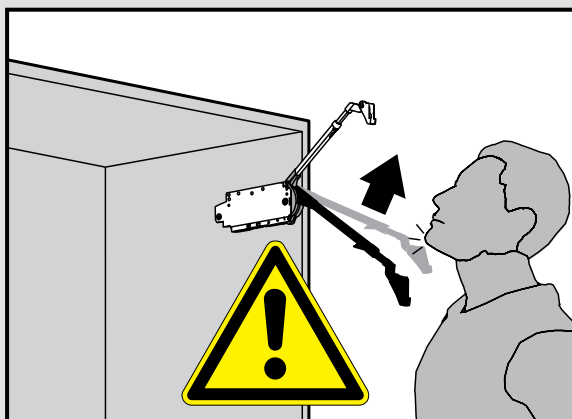

Verletzungsgefahr durch hochspringenden Teleskophebel!
 Risk of injury by spring-loaded telescopic arm!
 Risque de blessure en cas de relevage brusque du bras télescopique !
 Pericolo di lesioni a causa del possibile scatto verso l'alto della leva telescopica!
 Peligro de lesiones por salto de la palanca telescópica.
 Niebezpieczeństwo zranienia przez gwałtownie unoszący się podnośnik teleskopowy!
 Существует опасность получения травмы при резком подъеме телескопического рычага!
 アームが跳ね上がってケガをする可能性があります。

Teleskophebel nicht nach unten drücken, sondern entfernen.
 Do not push telescopic arm down without door attached but remove.
 Ne pas pousser le bras télescopique vers le bas, mais le retirer.
 Non spingere la leva telescopica verso il basso, altrimenti rimuoverlo.
 No apretar la palanca telescópica hacia abajo, si no retirarlo.
 Nie opuszczać podnośnika teleskopowego, lecz wyjąć.
 Не опускайте рычаги. В случае необходимости их следует снимать.
 アームを外す時は下に押さないでください。

5

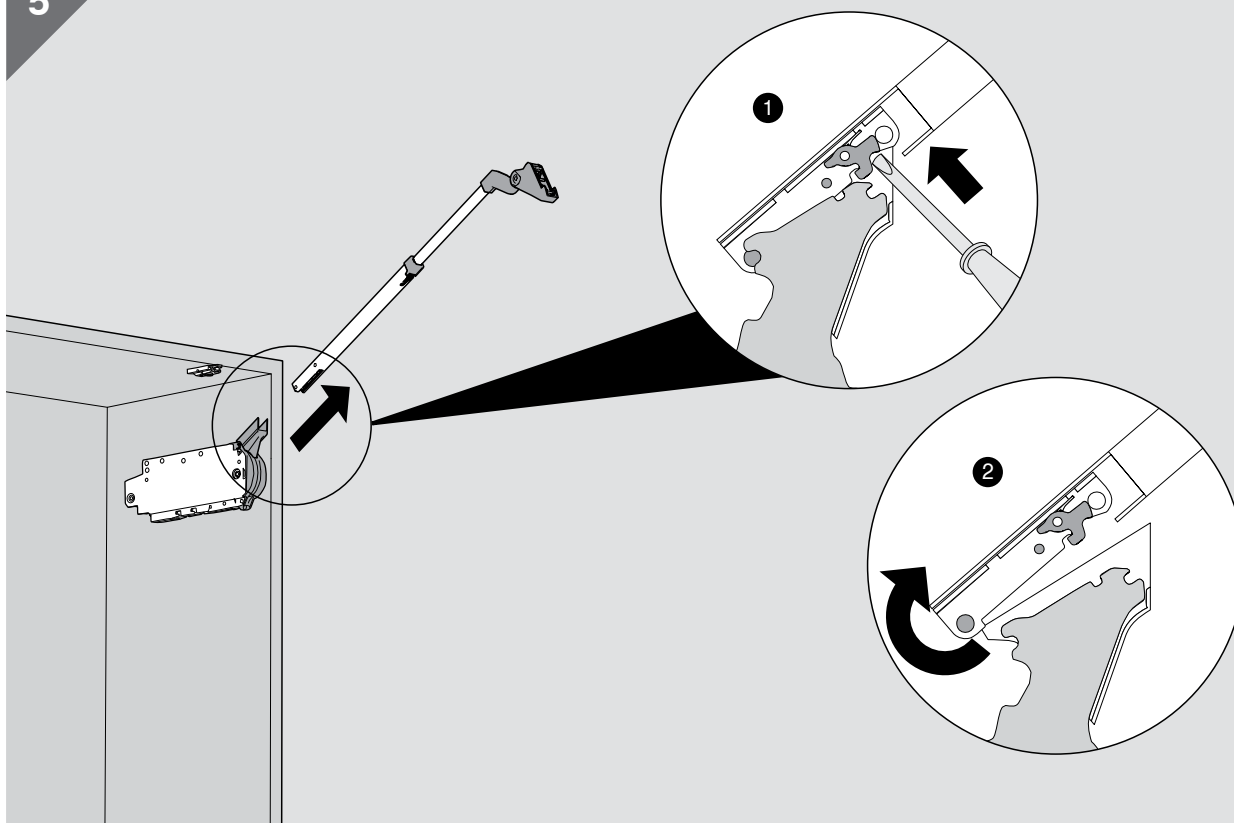

AVENTOS HF





WARNING | WARNING | AVERTISSEMENT |
AVVERTENZA | ADVERTENCIA | OSTRZEŻENIE |
ВНИМАНИЕ | 警告

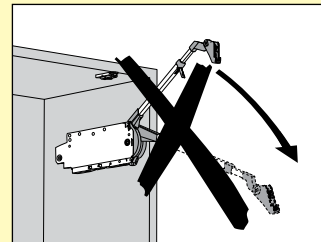
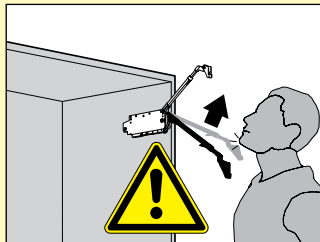

AR	الذراع المتداخل يندفع بقوة مما قد يحدث جرح	لا تقوم بدفع الذراع المتداخل الى اسفل
BG	Опасност от нараняване при повдигане на телескопичната опора!	Телескопичната опора да не се натиска надолу, а да се отстранява.
CS	Nebezpečí zranění z důvodu vystřelujícího teleskopu!	Netlačte teleskop směrem dolů, nýbrž ji odstraňte.
DA	Risiko for at komme til skade ved opsvingning af teleskopstang!	Teleskopstang må ikke trykkes nedad, men fjernes.
DE	Verletzungsgefahr durch hochspringenden Teleskophebel!	Teleskophebel nicht nach unten drücken, sondern entfernen.
EL	Το τηλεσκοπικό μπράτσο μπορεί να πεταχτεί προς τα επάνω και να προκαλέσει τραυματισμό.	Μην σπρώχνετε προς τα κάτω το τηλεσκοπικό μπράτσο.
EN	Risk of injury by spring-loaded telescopic arm!	Do not push telescopic arm down without door attached.
ES	Peligro de lesiones por salto de la palanca telescópica.	No apretar la palanca telescópica hacia abajo, si no retirarlo.
ET	Teleskoophoob võib viskuda üles ja põhjustada trauma	Ära tõmba alla teleskoophooba.
FI	Loukkaantumisvaara – varsi voi ponnahtaa ylöspäin!	Älä paina vartta alaspäin, vaan se pitää poistaa!
FR	Risque de blessure en cas de relevage brusque du bras télescopique !	Ne pas pousser le bras télescopique vers le bas, mais le retirer.
HR	Opasnost od ozljeda uslijed teleskopske poluge koja iskače!	Teleskopsku polugu ne pritišćite prema dolje, već ga uklonite.
HU	Sérülésveszély a felugró teleszkópos emelőkar miatt!	A teleszkópos emelőkart nem szabad lefelé nyomni!
IT	Pericolo di lesioni a causa del possibile scatto verso l'alto della leva telescopica!	Non spingere la leva telescopica verso il basso, altrimenti rimuoverlo.
IW	הזרוע הטלסקופית עלולה לקפוץ כלפי מעלה ולגרום לפציעה	אסור לדחוף את הזרוע הטלסקופית כלפי מטה
JA	アームが跳ね上がってケガをする可能性があります。	アームを外す時は下に押さないでください。
LT	Teleskopinis svertas gali atšokti ir rimtai sužeisti.	Niekada nespaukite žemyn sverto.
LV	Teleskopiskais kronšteins var strauji atvērties uz augšu un radīt traumu.	Nespiediet uz leju teleskopisko kronšteinu.
NL	Risico tot kwetsuren door omhoogspringende telescopische arm!	Telescopische arm niet naar onder duwen maar verwijderen.
NO	Kraftig fjærpakke. Fare for skade !	Ikke press teleskoparmen ned ! Demonter før montering av skrog.
PL	Niebezpieczeństwo zranienia przez gwałtownie unoszący się podnośnik teleskopowy!	Nigdy nie opuszczaj teleskopowego, lecz wyjąć.
PT	Perigo de ferimento, devido ao brusco salto da alavanca telescópica.	Não pressionar a alavanca telescópica para baixo, mas sim removê-la.
RO	Pericol de rănire prin brațul telescopic aflat sub tensiunea produsă de arcuri!	Nu apăsați în jos brațul telescopic, ci îndepărtați-l.
RU	Существует опасность получения травмы при резком подъеме телескопического рычага!	Не опускайте рычаги. В случае необходимости их следует снимать.
SK	Riziko poranenia kvôli vyskakujúcemu teleskopu!	Netlačte teleskop smerom dole, ale ich odstráňte.
SL	Nevarnost poškodbe zaradi teleskopske ročice, ki lahko odskoči!	Teleskopske ročice ne potiskajte navzdol, ampak ga odstranite.
SR	Opasnost od povreda usled iskakajuće teleskopske poluge!	Teleskopsku polugu ne pritiskati nadole, već skinuti.
SV	Skaderisk vid obelastad teleskoparm!	Tryck inte ned teleskoparmen, utan ta bort den.
TR	Teleskopik kol sıçrayabileceği için yaralanma tehlikesi!	Teleskopik kol aşağı doğru bastırılmamalıdır, çıkarılmalıdır.
UK	Загроза травмування з причини різкого піднімання телескопічного важеля!	Не опускати до низу телескопічний важіль. Його необхідно зняти.
ZH	伸缩臂上弹会伤害到人！	伸缩臂请勿下压，请务必取下。